

CHESHIRE CUSTOM HOME

Framing and Foundations

9271 SE. 76th Street, Mercer Island, WA 98040

Prepared for: FormWorks Design Build



Date: August 12th, 2021

By: Kevin J. Haiar P.E.

August 12th, 2021

Summary

The project involves a new two-story wood framed custom home with basement and involves a total footprint of about 48 ft x 40 ft. The house includes two decks, a large cantilevered roof overhang, and some site retaining walls. The framing system consists of 12" deep engineering joists and involves conventional wood shear walls for lateral resistance to wind and seismic forces. Footings comprise of conventional concrete pad and strip footings.

Design Codes

2018 International Building Code
ASCE/SEI 7-16
NDS Wood Design 2015
ACI 318 Concrete 2014

Design Criteria

Roof Snow Load:	25 psf + 5 psf rain on snow
Importance Factor:	1.0
Wind Speed:	110 mph
Wind Exposure:	C
Seismic Design Category:	D
Seismic S _s :	1.472
Seismic S ₁ :	0.566
Allowable Soil Bearing:	2000 psf (assume)

COVID-19 Information & Resources



City of
MERCER ISLAND

Community Services Departments Government

[Search Our Site](#)

COVID-19 CPD and Construction Information

Community Planning & Development

The City is working on reopening and restarting various programs. City Hall will reopen to the public in September. Follow this link for the latest information.

[Permits, Plan Review, & Inspections](#)

[Land Use and Planning](#)

[How to Apply](#)

[Target Times & Reviews](#)

[Fees](#)

[Weekly Permit Information Bulletin](#)

[City Code](#)

[Design Commission](#)

[Planning Commission](#)

Climatic and Geographic Design Criteria

IRC TABLE R301.2 (1)
Climatic and Geographic Design Criteria

Roof Snow Load ^a	Wind Design ^b		Seismic Design Category ^c	Subject to Damage From:			Outside Design Temp-Heat/Cool	Ice Barrier Under-layment Required	Flood Hazards ^e	Air Freezing Index	Mea Ann Tem
	Speed	Topographic Effects		Weathering ^d	Frost Line Depth	Termite Decay					
25 psf	110 mph	See footnote ^b	D2	Moderate	12"	Slight to Moderate	24°F/83°F	No	NA	113	53°

- A. When using this roof snow load it will be left to the engineer's judgment whether to consider drift or sliding snow. However, rain on snow surcharge of 5 psf must be considered for roof slopes less than 5 degrees.
- B. Wind exposure category and Topographic effects (Wind Speed-up Kzt factor) shall be determined on a site-specific basis by the Engineer of Record (components and cladding need not consider topographic effects unless otherwise determined by the engineer of record).
- C. From IRC Table 301.2(1).
- D. Weathering may require a higher strength concrete or grade of masonry than necessary to satisfy the structural requirements of this code. The grade of masonry units shall be determined from ASTM C 34, C 55, C 62, C 73, C 90, C 129, C 145, C 216 or C 652.
- E. The City of Mercer Island participates in the National Flood Insurance Program (NFIP); Regular Program (No Special Flood Hazard Area). Further NFIP participation information: CID 530083, Initial FIRM identified 06/28/74, Initial FIRM identified 05/16/95, Current Effective Map Date (NSFHA), Reg-Emer Date 06/30/97.

Gravity Loads

<u>Roof Dead Loads:</u>	<u>Weight (psf)</u>
Roofing	1.0
Decking	2.0
Roof Joists/Trusses	2.0
Insulation	1.0
Gyp Ceiling	2.5
Mech/Elec	1.5
Misc.	5.0

Total Roof Dead Load **15.0**

<u>Roof Live Loads:</u>	<u>Weight (psf)</u>
Roof Live Load	20.0
Snow Load + 5psf rain on snow	30.0

<u>Ext. Wall Dead Loads:</u>	<u>Weight (psf)</u>
6" studs	1.8
Sheathing, 15/32"	1.5
Insulation	1.2
Ext finish (siding)	3
Misc	2.5

Total Wall Load **10**

<u>Floor Dead Loads:</u>	<u>Weight (psf)</u>
Flooring	1.0
Gypcrete/overlay (2")	19.2
Joists	2.0
Gyp Ceiling	2.5
Mech/Elec	1.5
Misc.	3.8

Total Floor Dead Load **30.0**

<u>Floor Live Loads:</u>	<u>Weight (psf)</u>
Residential	40

Footing Bearing:

Grid 2 - Worst Case Loading			
Tributary	20		ft
Dead	1499		lbs
Live	1600		lbs
Snow	600		lbs
D+L	3099		lbs
D+0.75L+0.75S	3149		lbs
Allowable Bearing Pressure	2000		psf
Minimum Footing Width	1.57		ft

USE 2FT-6IN WIDE X 12" DP FOOTING AT INT BRG WALLS AND EXT STUD WALLS

Roof & Floor Framing Beams

BM #	Description	location	Span ft	Roof Trib ft	R DL PLF	Roof S PLF	Roof Live PLF	Floor Trib ft	FL Live PSF	FL Dead PLF	FL Live PLF	Beam Size	Reactions
BM 1	Typ Rf Ext Hdr	Roof Grid 3	5.5	7.5	112.5	225	150	0	0	0	0	(2) 2x10 DFL #2	773
Bm 2	Typ Rf Int Hdr	Roof Grid 2	3	20	300	600	400	0	0	0	0	(2) 2x10 DFL #2	1125
BM 3	Rf East Cantilever	Rf grid 1 & 2	19	10.5	157.5	315	210	0	0	0	0	GL 5.125x10.5 V8	6891
BM 4	2nd flr ext hdr	2nd grid 1 & 2	11.25	10	150	300	200	11	40	330	440	GL 5.125x10.5 V4	2923
BM 5	Typ frl hdr	1st & 2nd, all grids	5.5	10	150	300	200	10	40	300	400	(2) 2x10 DFL #2	1347
BM 6	Garage hdr	1st flr grid 1	16.5	10	150	300	200	20	40	599	800	GL 5.125x18 V4	6512
BM 7	Deck beam	1st flr grid B'	6.5	0	0	0	0	7	40	210	280	(2) 2x10 DFL #2	812

NOTES:

1. SEE ENERCALC OUTPUT SHEETS FOR BEAM DESIGNS
2. TOTAL LOAD INCLUDES LOAD CASES D+L, $D=0.75*L+0.75*S$

INDICATES SHEAR WALL LOCATIONS

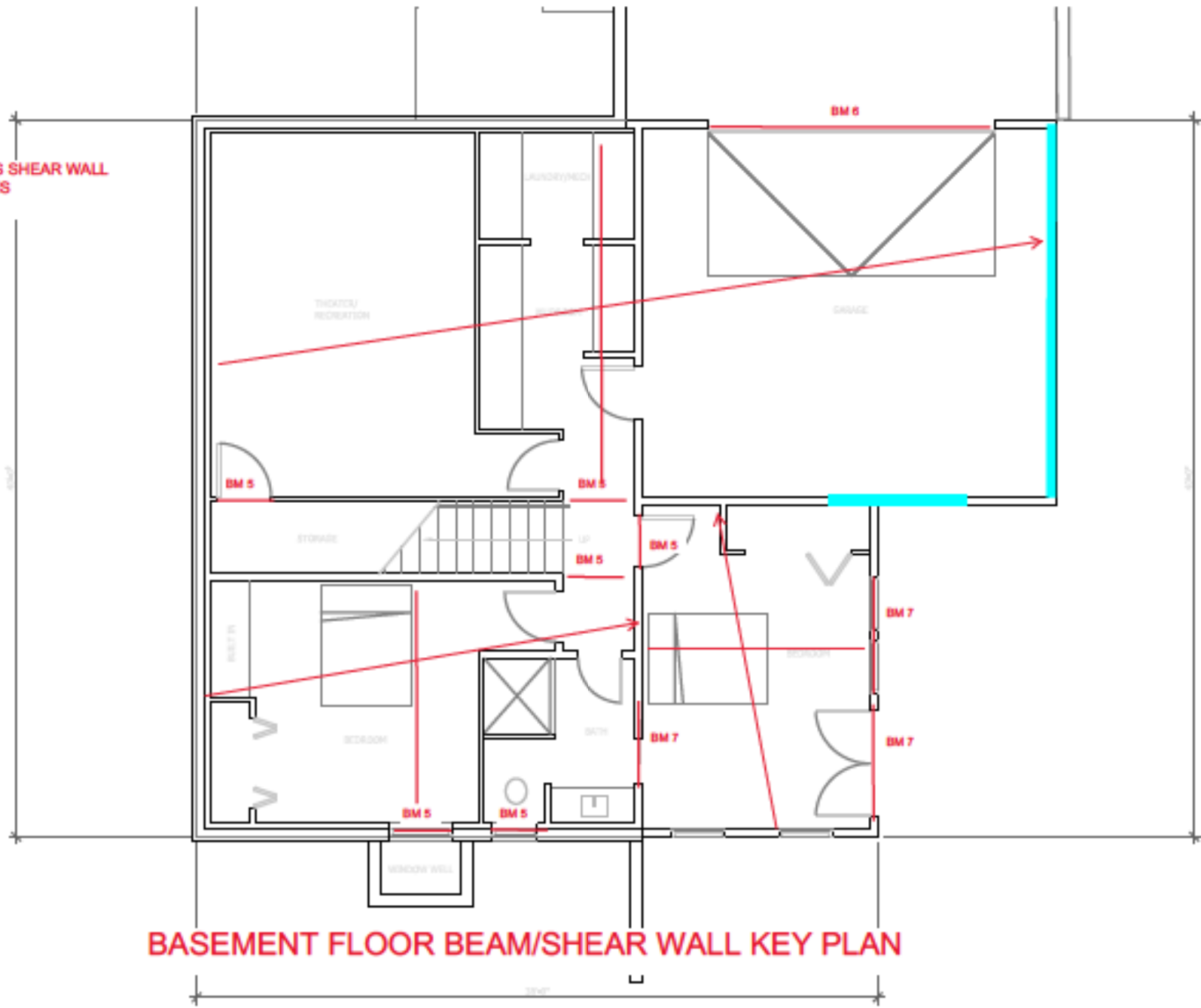

BASEMENT FLOOR BEAM/SHEAR WALL KEY PLAN

INDICATES SHEAR WALL LOCATIONS

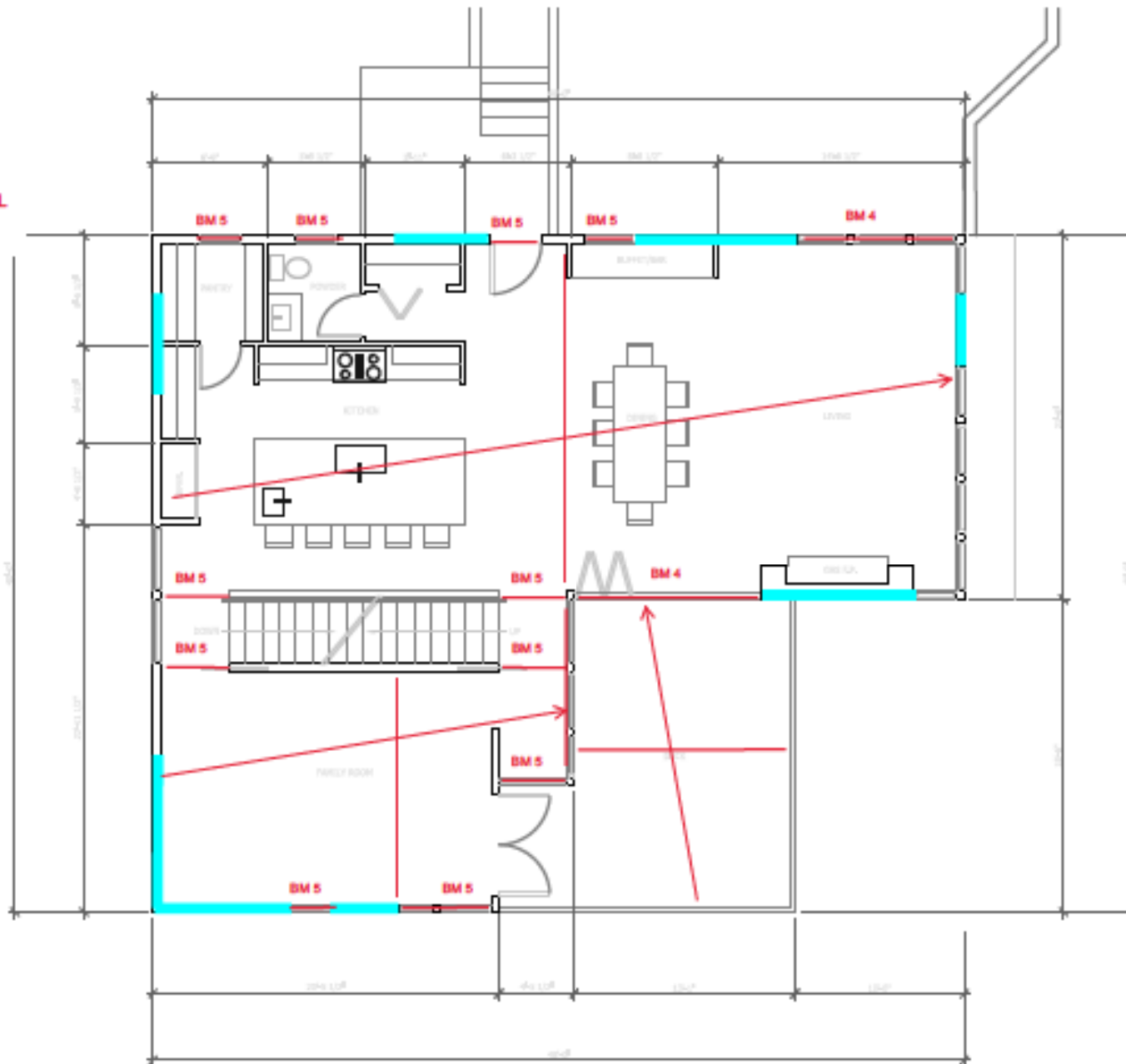

MAIN FLOOR BEAM/SHEAR WALL KEY PLAN

INDICATES SHEAR WALL LOCATIONS

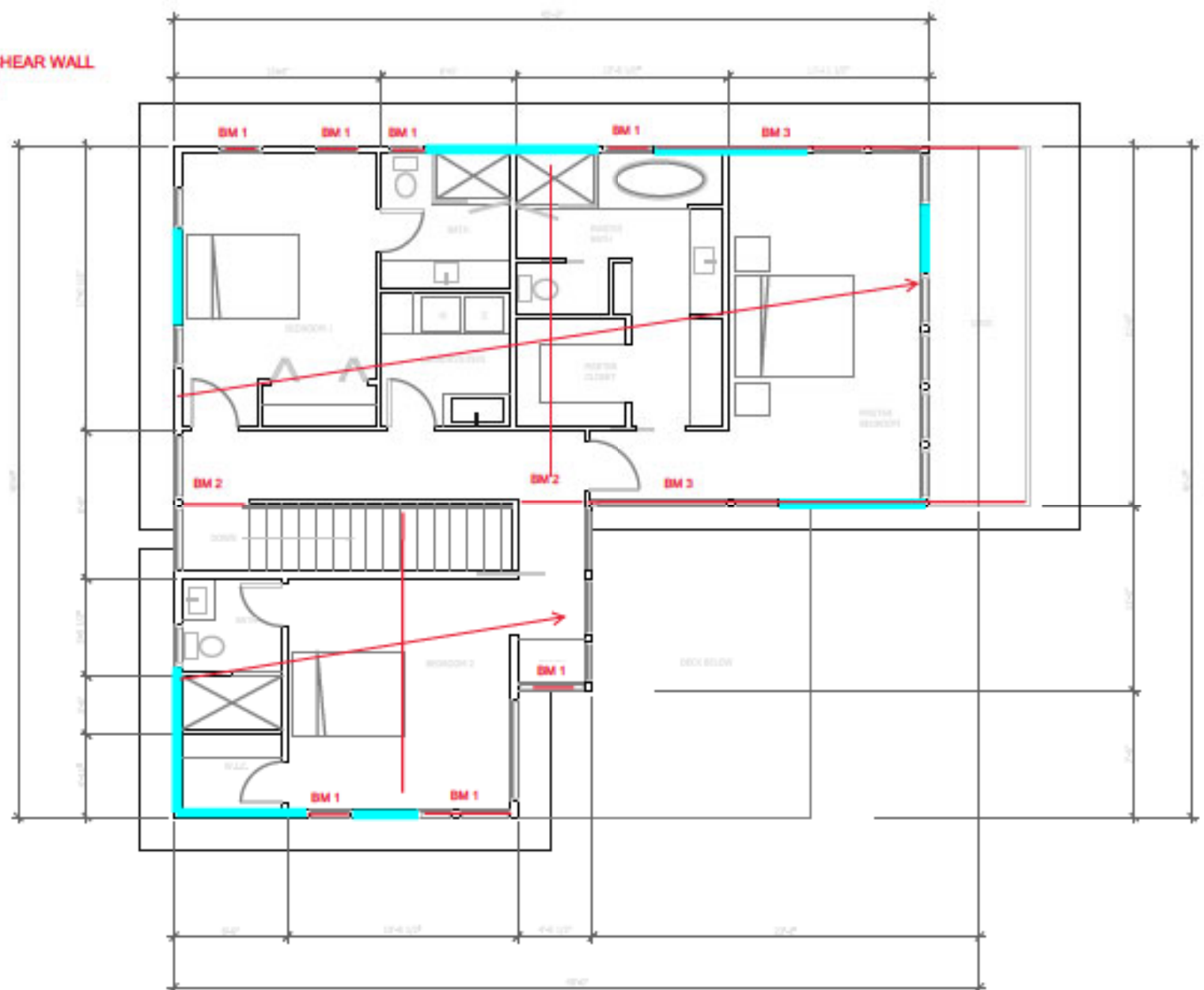

SECOND FLOOR BEAM/SHEAR WALL KEY PLAN



RedSpec™ by RedBuilt™
v7.1.12

Project: Project
Location: Mercer Island, WA
Folder: Folder
Date: 8/8/21 6:10 PM
Designer: KJH
Comment:

Type: FLOOR JOISTS

11.875" Red-I58™ @ 16" o.c. with Glued Sheathing

This product meets or exceeds the set design controls for the application and loads listed

DESIGN CONTROLS	%	Design	Allow.	DOL	Combination	Pattern	Pass/Fail	
Shear (lb)	55%	980	1785	Floor(100%)	1.0D+1.0L	All Spans	PASS	
Positive Moment (ft-lb)	82%	5145	6255	Floor(100%)	1.0D+1.0L	All Spans	PASS	
DEFLECTIONS (in)	%	Design	Allow.	Design	Allow.	Combination	Pattern	Pass/Fail
Span Live	99%	0.519	0.525	L / 486	L / 480	1.0D+1.0L	All Spans	PASS
Span Total	86%	0.908	1.050	L / 278	L / 240	1.0D+1.0L	All Spans	PASS

FloorChoice™ Rating: 0.9



Performance rating is based on: 24 oc (23/32", 3/4") sheathing, glued and nailed, 1 1/2" Lightweight Concrete topping, 1 Row Blocking, 1/2" Gypsum ceiling, simple span, rigid supports. RedSpec has not performed a structural analysis of the sheathing.

SUPPORTS	Support 1	Support 2
Live Reaction, Critical (lb) (DOL%)	560 (100)	560 (100)
Dead Reaction (lb)	420	420
Total Reaction (lb) (DOL%)	980 (100)	980 (100)
Bearing Support	Bottom Wall	Flush Wall
Req'd Bearing, No Stiffeners (in)	1.75	1.75
Req'd Bearing, Stiffeners (in)	-	-

HANGERS	Model	Top	Face	Member	Header	Size
Right	None Selected					

SPANS AND LOADS

Dimensions represent horizontal design spans.

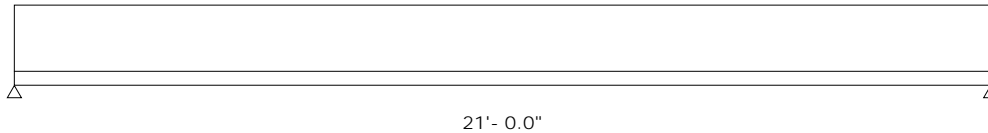

APPLICATION LOADS

Type	Units	DOL	Live	Dead	Partition	Tributary	Member Type
Uniform	psf	Floor(100%)	40	30	0	16"	Glued Floor Joist

NOTES

- Building code and design methodology: 2018 IBC ASD (US).
- Product Acceptance: ICC-ES ESR-2994 and LABC/LARC Supplement.
- Deflection analysis is based on composite action with 24 oc (23/32", 3/4") sheathing, glued and nailed.
- Continuous lateral support required at top edge. Lateral support at bottom edge shall be per RedBuilt recommendations.

C:\Users\Kevin\Dropbox\MDS_SHARED\DESIGN PROJECTS-MDS\MDS PROJECTS 2021\21-045 Mercer Island Custom Home\CALCS\REDBUILT\Mercer.red

8/8/2021 6:10:10 PM

Project : Folder : FLOOR JOISTS

Page 1 of 1

The products noted are intended for interior, untreated, non-corrosive applications with normal temperatures and dry conditions of use, and must be installed in accordance with local building code requirements and RedBuilt™ recommendations. The loads, spans, and spacing have been provided by others and must be approved for the specific application by the design professional for the project. Unless otherwise noted, this output has not been reviewed by a RedBuilt™ associate. PRODUCT SUBSTITUTION VOIDS THIS ANALYSIS.

RedBuilt™, RedSpec™, Red-I™, Red-I45™, Red-I45L™, Red-I58™, Red-I65™, Red-I90™, Red-I90H™, Red-I90HS™, Red-L™, Red-W™, Red-S™, Red-M™, Red-H™, RedLam™, FloorChoice™ are trademarks of RedBuilt LLC, Boise ID, USA. Copyright © 2010-2020 RedBuilt LLC. All rights reserved.



RedSpec™ by RedBuilt™
v7.1.12

Project: Project
Location: Mercer Island, WA
Folder: Folder
Date: 8/8/21 6:11 PM
Designer: KJH
Comment:

Type: ROOF JOISTS

11.875" Red-I45L™ @ 16" o.c.

This product meets or exceeds the set design controls for the application and loads listed

DESIGN CONTROLS	%	Design	Allow.	DOL	Combination	Pattern	Pass/Fail
Shear (lb)	32%	630	1955	Snow(115%)	1.0D+1.0S	All Spans	PASS
Positive Moment (ft-lb)	91%	3308	3651	Snow(115%)	1.0D+1.0S	All Spans	PASS

DEFLECTIONS (in)	%	Design	Allow.	Design	Allow.	Combination	Pattern	Pass/Fail
Span Live	95%	0.668	0.700	L / 377	L / 360	1.0D+1.0S	All Spans	PASS
Span Total	95%	1.002	1.050	L / 252	L / 240	1.0D+1.0S	All Spans	PASS

SUPPORTS	Support 1	Support 2
Live Reaction, Critical (lb) (DOL%)	420 (115)	420 (115)
Dead Reaction (lb)	210	210
Total Reaction (lb) (DOL%)	630 (115)	630 (115)
Bearing Support	Bottom Wall	Flush Wall
Req'd Bearing, No Stiffeners (in)	1.75	1.75
Req'd Bearing, Stiffeners (in)	-	-

HANGERS	Model	Top	Face	Member	Header	Size
Right	None Selected					

SPANS AND LOADS

Dimensions represent horizontal design spans.

Member Slope: 0/12

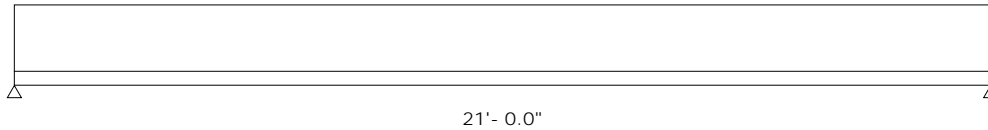

APPLICATION LOADS

Type	Units	DOL	Live	Dead	Partition	Tributary	Member Type
Uniform	psf	Snow(115%)	30	15	0	16"	Snow Roof Joist

NOTES

- Building code and design methodology: 2018 IBC ASD (US).
- Product Acceptance: ICC-ES ESR-2994 and LABC/LARC Supplement.
- Continuous lateral support required at top edge. Lateral support at bottom edge shall be per RedBuilt recommendations.

C:\Users\Kevin\Dropbox\MDS_SHARED\DESIGN PROJECTS-MDS\MDS PROJECTS 2021\21-045 Mercer Island Custom Home\CALCS\REDBUILT\Mercer.red

The products noted are intended for interior, untreated, non-corrosive applications with normal temperatures and dry conditions of use, and must be installed in accordance with local building code requirements and RedBuilt™ recommendations. The loads, spans, and spacing have been provided by others and must be approved for the specific application by the design professional for the project. Unless otherwise noted, this output has not been reviewed by a RedBuilt™ associate. PRODUCT SUBSTITUTION VOIDS THIS ANALYSIS.

RedBuilt™, RedSpec™, Red-I™, Red-I45™, Red-I45L™, Red-I58™, Red-I65™, Red-I90™, Red-I90H™, Red-I90HS™, Red-L™, Red-W™, Red-S™, Red-M™, Red-H™, RedLam™, FloorChoice™ are trademarks of RedBuilt LLC, Boise ID, USA. Copyright © 2010-2020 RedBuilt LLC. All rights reserved.



Wood Column

Lic. #: KW-06011847

DESCRIPTION Typical Stud Design (2x6's at 16" oc)

Code References

Calculations per NDS 2015, IBC 2015, CBC 2016, ASCE 7-10
 Load Combinations Used : ASCE 7-10

General Information

Analysis Method	Allowable Stress Design			Wood Section Name	2x6	
End Fixities	Top & Bottom Pinned			Wood Grading/Manuf.	Graded Lumber	
Overall Column Height	9 ft			Wood Member Type	Sawn	
<i>(Used for non-slender calculations)</i>						
Wood Species	Douglas Fir-South			Exact Width	1.50 in	
Wood Grade	No.2			Exact Depth	5.50 in	
Fb +	850 psi	Fv	180 psi	Area	8.250 in ²	
Fb -	850 psi	Ft	525 psi	Ix	20.797 in ⁴	
Fc - Prll	1350 psi	Density	28.72 pcf	Iy	1.547 in ⁴	
Fc - Perp	520 psi					
E : Modulus of Elasticity	. . . x-x Bending y-y Bending Axial			Allow Stress Modification Factors		
	Basic	1200	1200	1200 ksi	Cf or Cv for Bending	1.30
	Minimum	440	440		Cf or Cv for Compression	1.10
					Cf or Cv for Tension	1.30
					Cm : Wet Use Factor	1.0
					Ct : Temperature Fact	1.0
					Cfu : Flat Use Factor	1.0
					Kf : Built-up columns	1.0 <i>NDS 15.3.2</i>
					Use Cr : Repetitive	No
Brace condition for deflection (buckling) along columns :						
X-X (width) axis Fully braced against buckling ABOUT Y-Y Axis						
Y-Y (depth) axis Unbraced Length for buckling ABOUT X-X Axis = 9						

Applied Loads

Service loads entered. Load Factors will be applied for calculations.

Column self weight included : 14.809 lbs * Dead Load Factor

AXIAL LOADS . . .

Axial Load at 9.0 ft, D = 1.50, L = 1.60, S = 0.60 k

BENDING LOADS . . .

Lat. Uniform Load creating Mx-x, W = 0.040 k/ft

DESIGN SUMMARY

Bending & Shear Check Results

PASS Max. Axial+Bending Stress Ratio = **0.4895 : 1**

Load Combination	+D+L
Governing NDS Formula	Comp Only, fc/Fc'
Location of max.above base	0.0 ft
At maximum location values are .	
Applied Axial	3.115 k
Applied Mx	0.0 k-ft
Applied My	0.0 k-ft
Fc : Allowable	771.29 psi

Maximum SERVICE Lateral Load Reactions . .

Top along Y-Y	0.180 k	Bottom along Y-Y	0.180 k
Top along X-X	0.0 k	Bottom along X-X	0.0 k

Maximum SERVICE Load Lateral Deflections . . .

Along Y-Y	0.2392 in at	4.530 ft above base
for load combination : W Only		
Along X-X	0.0 in at	0.0 ft above base
for load combination : n/a		

Other Factors used to calculate allowable stresses . . .

	<u>Bending</u>	<u>Compression</u>	<u>Tension</u>
--	----------------	--------------------	----------------

PASS Maximum Shear Stress Ratio = **0.06818 : 1**

Load Combination	+D+0.60W
Location of max.above base	9.0 ft
Applied Design Shear	19.636 psi
Allowable Shear	288.0 psi

Load Combination Results

Load Combination	C _D	C _P	Maximum Axial + Bending Stress Ratios			Maximum Shear Ratios		
			Stress Ratio	Status	Location	Stress Ratio	Status	Location
D Only	0.900	0.560	0.2455	PASS	0.0 ft	0.0	PASS	9.0 ft
+D+L	1.000	0.519	0.4895	PASS	0.0 ft	0.0	PASS	9.0 ft
+D+S	1.150	0.467	0.3212	PASS	0.0 ft	0.0	PASS	9.0 ft
+D+0.750L	1.250	0.437	0.4054	PASS	0.0 ft	0.0	PASS	9.0 ft
+D+0.750L+0.750S	1.150	0.467	0.4807	PASS	0.0 ft	0.0	PASS	9.0 ft
+D+0.60W	1.600	0.356	0.3184	PASS	4.470 ft	0.06818	PASS	9.0 ft
+D+0.750L+0.450W	1.600	0.356	0.4037	PASS	4.470 ft	0.05114	PASS	9.0 ft
+D+0.750L+0.750S+0.450W	1.600	0.356	0.4829	PASS	4.470 ft	0.05114	PASS	9.0 ft
+0.60D+0.60W	1.600	0.356	0.2641	PASS	4.470 ft	0.06818	PASS	9.0 ft



Project Title: Mercer Island Custom Home
 Engineer: KJH
 Project ID: 21-045
 Project Descr: Framing and Foundations

Printed: 9 AUG 2021, 12:33AM

Wood Column

Software copyright ENERCALC, INC. 1983-2020, Build:12.20.8.24

Lic. # : KW-06011847

Merrell Design Services PLLC

DESCRIPTIO Typical Stud Design (2x6's at 16" oc)

Load Combination Results

Load Combination	C _D	C _P	Maximum Axial + Bending Stress Ratios			Maximum Shear Ratios		
			Stress Ratio	Status	Location	Stress Ratio	Status	Location
+0.60D	1.600	0.356	0.1304	PASS	0.0 ft	0.0	PASS	9.0 ft



Wood Column

Lic. #: KW-06011847

DESCRIPTION Double Stud Post

Code References

Calculations per NDS 2015, IBC 2015, CBC 2016, ASCE 7-10
 Load Combinations Used : ASCE 7-16

General Information

Analysis Method	Allowable Stress Design			Wood Section Name	2-2x6
End Fixities	Top & Bottom Pinned			Wood Grading/Manuf.	Graded Lumber
Overall Column Height	9 ft			Wood Member Type	Sawn
<i>(Used for non-slender calculations)</i>					
Wood Species	Douglas Fir-South			Exact Width	3.0 in
Wood Grade	No.2			Exact Depth	5.50 in
Fb +	850 psi	Fv	180 psi	Area	16.50 in ²
Fb -	850 psi	Ft	525 psi	Ix	41.594 in ⁴
Fc - Prll	1350 psi	Density	28.72 pcf	Iy	12.375 in ⁴
Fc - Perp	520 psi			Allow Stress Modification Factors	
E : Modulus of Elasticity . . .	x-x Bending	y-y Bending	Axial	Cf or Cv for Bending	1.30
Basic	1200	1200	1200 ksi	Cf or Cv for Compression	1.10
Minimum	440	440		Cf or Cv for Tension	1.30
				Cm : Wet Use Factor	1.0
				Ct : Temperature Fact	1.0
				Cfu : Flat Use Factor	1.0
				Kf : Built-up columns	1.0 <small>NDS 15.3.2</small>
				Use Cr : Repetitive	No
Brace condition for deflection (buckling) along columns :					
X-X (width) axis Fully braced against buckling ABOUT Y-Y Axis					
Y-Y (depth) axis Unbraced Length for buckling ABOUT X-X Axis = 9					

Applied Loads

Service loads entered. Load Factors will be applied for calculations.

Column self weight included : 29.618 lbs * Dead Load Factor

AXIAL LOADS . . .

Axial Load at 9.0 ft, D = 3.0, L = 4.0 k

BENDING LOADS . . .

Lat. Uniform Load creating Mx-x, W = 0.160 k/ft

DESIGN SUMMARY

Bending & Shear Check Results

PASS Max. Axial+Bending Stress Ratio = **0.7230 : 1**
 Load Combination +D+0.750L+0.450W
 Governing NDS Formula $\sigma_{comp} + M_{xx}$, NDS Eq. 3.9-3
 Location of max. above base 4.470 ft
 At maximum location values are .
 Applied Axial 6.030 k
 Applied Mx 0.7290 k-ft
 Applied My 0.0 k-ft
 Fc : Allowable 844.78 psi

Maximum SERVICE Lateral Load Reactions . .
 Top along Y-Y 0.720 k Bottom along Y-Y 0.720 k
 Top along X-X 0.0 k Bottom along X-X 0.0 k

Maximum SERVICE Load Lateral Deflections . . .
 Along Y-Y 0.4783 in at 4.530 ft above base
 for load combination : W Only
 Along X-X 0.0 in at 0.0 ft above base
 for load combination : n/a

Other Factors used to calculate allowable stresses . . .
 Bending Compression Tension

PASS Maximum Shear Stress Ratio = **0.1364 : 1**
 Load Combination +D+0.60W
 Location of max. above base 9.0 ft
 Applied Design Shear 39.273 psi
 Allowable Shear 288.0 psi

Load Combination Results

Load Combination	C _D	C _P	Maximum Axial + Bending Stress Ratios			Maximum Shear Ratios		
			Stress Ratio	Status	Location	Stress Ratio	Status	Location
D Only	0.900	0.560	0.2455	PASS	0.0 ft	0.0	PASS	9.0 ft
+D+L	1.000	0.519	0.5524	PASS	0.0 ft	0.0	PASS	9.0 ft
+D+0.750L	1.250	0.437	0.4501	PASS	0.0 ft	0.0	PASS	9.0 ft
+D+0.60W	1.600	0.356	0.5896	PASS	4.470 ft	0.1364	PASS	9.0 ft
+D+0.750L+0.450W	1.600	0.356	0.7230	PASS	4.470 ft	0.1023	PASS	9.0 ft
+0.60D+0.60W	1.600	0.356	0.5112	PASS	4.470 ft	0.1364	PASS	9.0 ft
+0.60D	1.600	0.356	0.1304	PASS	0.0 ft	0.0	PASS	9.0 ft



Project Title: Mercer Island Custom Home
 Engineer: KJH
 Project ID: 21-045
 Project Descr: Framing and Foundations

Printed: 9 AUG 2021, 12:29AM

Wood Column

Software copyright ENERCALC, INC. 1983-2020, Build:12.20.8.24

Lic. #: KW-06011847

Merrell Design Services PLLC

DESCRIPTION Double Stud Post

Code References

Calculations per NDS 2015, IBC 2015, CBC 2016, ASCE 7-10
 Load Combinations Used : ASCE 7-10

General Information

Analysis Method	Allowable Stress Design			Wood Section Name	2-2x6
End Fixities	Top & Bottom Pinned			Wood Grading/Manuf.	Graded Lumber
Overall Column Height	10 ft			Wood Member Type	Sawn
<i>(Used for non-slender calculations)</i>					
Wood Species	Douglas Fir-Larch			Exact Width	3.0 in
Wood Grade	No.2			Exact Depth	5.50 in
Fb +	900 psi	Fv	180 psi	Area	16.50 in ²
Fb -	900 psi	Ft	575 psi	Ix	41.594 in ⁴
Fc - Prll	1350 psi	Density	31.21 pcf	Iy	12.375 in ⁴
Fc - Perp	625 psi			Allow Stress Modification Factors	
E : Modulus of Elasticity . . .	x-x Bending	y-y Bending	Axial	Cf or Cv for Bending	
Basic	1600	1600	1600 ksi	1.30	
Minimum	580	580		Cf or Cv for Compression	
				1.10	
				Cf or Cv for Tension	
				1.30	
				Cm : Wet Use Factor	
				1.0	
				Ct : Temperature Fact	
				1.0	
				Cfu : Flat Use Factor	
				1.0	
				Kf : Built-up columns	
				1.0 NDS 15.3.2	
				Use Cr : Repetitive	
				No	

Brace condition for deflection (buckling) along columns :
 X-X (width) axis Fully braced against buckling ABOUT Y-Y Axis
 Y-Y (depth) axis Fully braced against buckling ABOUT X-X Axis

Applied Loads

Service loads entered. Load Factors will be applied for calculations.

Column self weight included : 35.761 lbs * Dead Load Factor

AXIAL LOADS . . .

Axial Load at 10.0 ft, D = 3.0, L = 3.0, S = 3.0 k

DESIGN SUMMARY

Bending & Shear Check Results

PASS Max. Axial+Bending Stress Ratio = **0.2674 : 1**
 Load Combination +D+0.750L+0.750S
 Governing NDS Formula Comp Only, fc/Fc'
 Location of max.above base 0.0 ft
 At maximum location values are .
 Applied Axial 7.536 k
 Applied Mx 0.0 k-ft
 Applied My 0.0 k-ft
 Fc : Allowable 1,707.75 psi

Maximum SERVICE Lateral Load Reactions . .
 Top along Y-Y 0.0 k Bottom along Y-Y 0.0 k
 Top along X-X 0.0 k Bottom along X-X 0.0 k

Maximum SERVICE Load Lateral Deflections . . .
 Along Y-Y 0.0 in at 0.0 ft above base
 for load combination : n/a
 Along X-X 0.0 in at 0.0 ft above base
 for load combination : n/a

Other Factors used to calculate allowable stresses . . .
Bending Compression Tension

PASS Maximum Shear Stress Ratio = **0.0 : 1**
 Load Combination +0.60D
 Location of max.above base 10.0 ft
 Applied Design Shear 0.0 psi
 Allowable Shear 288.0 psi

Load Combination Results

Load Combination	C _D	C _P	Maximum Axial + Bending Stress Ratios			Maximum Shear Ratios		
			Stress Ratio	Status	Location	Stress Ratio	Status	Location
D Only	0.900	1.000	0.1377	PASS	0.0 ft	0.0	PASS	10.0 ft
+D+L	1.000	1.000	0.2463	PASS	0.0 ft	0.0	PASS	10.0 ft
+D+S	1.150	1.000	0.2142	PASS	0.0 ft	0.0	PASS	10.0 ft
+D+0.750L	1.250	1.000	0.1726	PASS	0.0 ft	0.0	PASS	10.0 ft
+D+0.750L+0.750S	1.150	1.000	0.2674	PASS	0.0 ft	0.0	PASS	10.0 ft
+0.60D	1.600	1.000	0.04646	PASS	0.0 ft	0.0	PASS	10.0 ft



Project Title: Mercer Island Custom Home
 Engineer: KJH
 Project ID: 21-045
 Project Descr: Framing and Foundations

Printed: 9 AUG 2021, 12:29AM

Wood Beam

Software copyright ENERCALC, INC. 1983-2020, Build:12.20.8.24

Lic. #: KW-06011847

Merrell Design Services PLLC

DESCRIPTIO Deck Joists

CODE REFERENCES

Calculations per NDS 2015, IBC 2015, CBC 2016, ASCE 7-10
 Load Combination Set : ASCE 7-10

Material Properties

Analysis Method	Allowable Stress Design	Fb +	900 psi	E : Modulus of Elasti	
Load Combinati	ASCE 7-10	Fb -	900 psi	Ebend- xx	1600ksi
		Fc - Prll	1350 psi	Eminbend - x	580ksi
Wood Species	Douglas Fir-Larch	Fc - Perp	625 psi		
Wood Grade	No.2	Fv	180 psi		
		Ft	575 psi	Density	31.21pcf
Beam Bracing	Beam is Fully Braced against lateral-torsional buckling			Repetitive Member Stress Increa	

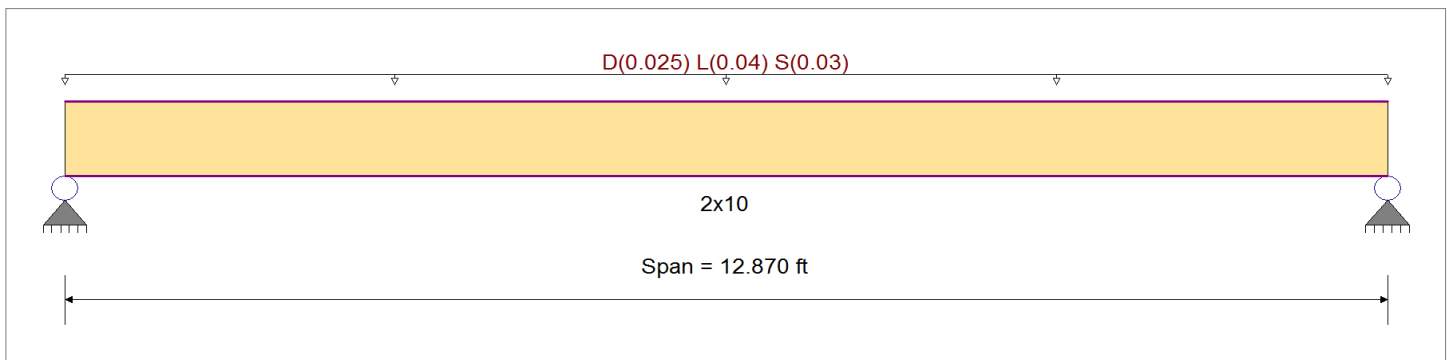

Applied Loads

Service loads entered. Load Factors will be applied for calculations.

Beam self weight calculated and added to loads

Uniform Load : D = 0.0250, L = 0.040, S = 0.030, Tributary Width = 1.0 ft

DESIGN SUMMARY

Design OK

Maximum Bending Stress Ratio	=	0.714 : 1	Maximum Shear Stress Ratio	=	0.239 : 1
Section used for this span		2x10	Section used for this span		2x10
fb: Actual	=	935.10psi	fv: Actual	=	49.47 psi
Fb: Allowable	=	1,309.28psi	Fv: Allowable	=	207.00 psi
Load Combination		+D+0.750L+0.750S	Load Combination		+D+0.750L+0.750S
Location of maximum on span	=	6.435ft	Location of maximum on span	=	0.000ft
Span # where maximum occurs	=	Span # 1	Span # where maximum occurs	=	Span # 1
Maximum Deflection					
Max Downward Transient Deflection		0.157 in	Ratio =		984 >=360
Max Upward Transient Deflection		0.000 in	Ratio =		0 <360
Max Downward Total Deflection		0.316 in	Ratio =		489 >=240
Max Upward Total Deflection		0.000 in	Ratio =		0 <240

Maximum Forces & Stresses for Load Combinations

Load Combination	Segment Length	Span #	Max Stress Ratios									Moment Values			Shear Values					
			M	V	C _d	C _{F/V}	C _i	C _r	C _m	C _t	C _L	M	fb	F'b	V	fv	F'v			
D Only	Length = 12.870 ft	1	0.317	0.106	0.90	1.100	1.00	1.15	1.00	1.00	1.00	0.58	325.31	1024.65	0.00	0.00	0.00	0.00	0.00	0.00
+D+L	Length = 12.870 ft	1				1.100	1.00	1.15	1.00	1.00	1.00	1.41	789.91	1138.50	0.00	0.00	0.00	0.00	0.00	0.00
+D+S	Length = 12.870 ft	1	0.694	0.232	1.00	1.100	1.00	1.15	1.00	1.00	1.00	1.20	673.76	1309.28	0.00	0.00	0.00	0.00	0.00	0.00
+D+0.750L	Length = 12.870 ft	1	0.515	0.172	1.15	1.100	1.00	1.15	1.00	1.00	1.00	1.20	673.76	1423.13	0.00	0.00	0.00	0.00	0.00	0.00
+D+0.750L+0.750S	Length = 12.870 ft	1	0.473	0.158	1.25	1.100	1.00	1.15	1.00	1.00	1.00	1.20	673.76	1423.13	0.00	0.00	0.00	0.00	0.00	0.00
+D+0.60D	Length = 12.870 ft	1	0.714	0.239	1.15	1.100	1.00	1.15	1.00	1.00	1.00	1.67	935.10	1309.28	0.00	0.00	0.00	0.00	0.00	0.00
	Length = 12.870 ft	1	0.107	0.036	1.60	1.100	1.00	1.15	1.00	1.00	1.00	0.35	195.18	1821.60	0.00	0.00	0.00	0.00	0.00	0.00



Project Title: Mercer Island Custom Home
 Engineer: KJH
 Project ID: 21-045
 Project Descr: Framing and Foundations

Printed: 9 AUG 2021, 12:29AM

Wood Beam

Software copyright ENERCALC, INC. 1983-2020, Build:12.20.8.24

Lic. # : KW-06011847

Merrell Design Services PLLC

DESCRIPTIO Deck Joists

Overall Maximum Deflections

Load Combination	Span	Max. "-" Defl	Location in Span	Load Combination	Max. "+" Defl	Location in Span
+D+0.750L+0.750S	1	0.3158	6.482		0.0000	0.000

Vertical Reactions

Support notation : Far left is #'

Values in KIPS

Load Combination	Support 1	Support 2
Overall MAXimum	0.518	0.518
Overall MINimum	0.193	0.193
D Only	0.180	0.180
+D+L	0.438	0.438
+D+S	0.373	0.373
+D+0.750L	0.373	0.373
+D+0.750L+0.750S	0.518	0.518
+0.60D	0.108	0.108
L Only	0.257	0.257
S Only	0.193	0.193



Wood Beam

Software copyright ENERCALC, INC. 1983-2020, Build:12.20.8.24
 Merrell Design Services PLLC

Lic. #: KW-06011847

DESCRIPTION Beam 1

CODE REFERENCES

Calculations per NDS 2015, IBC 2015, CBC 2016, ASCE 7-10
 Load Combination Set : ASCE 7-10

Material Properties

Analysis Method	Allowable Stress Design	Fb +	900 psi	E : Modulus of Elasticity	
Load Combination	ASCE 7-10	Fb -	900 psi	Ebend- xx	1600ksi
		Fc - Prll	1350 psi	Eminbend - x	580ksi
Wood Species	Douglas Fir-Larch	Fc - Perp	625 psi		
Wood Grade	No.2	Fv	180 psi		
		Ft	575 psi	Density	31.21pcf
Beam Bracing	Beam is Fully Braced against lateral-torsional buckling				

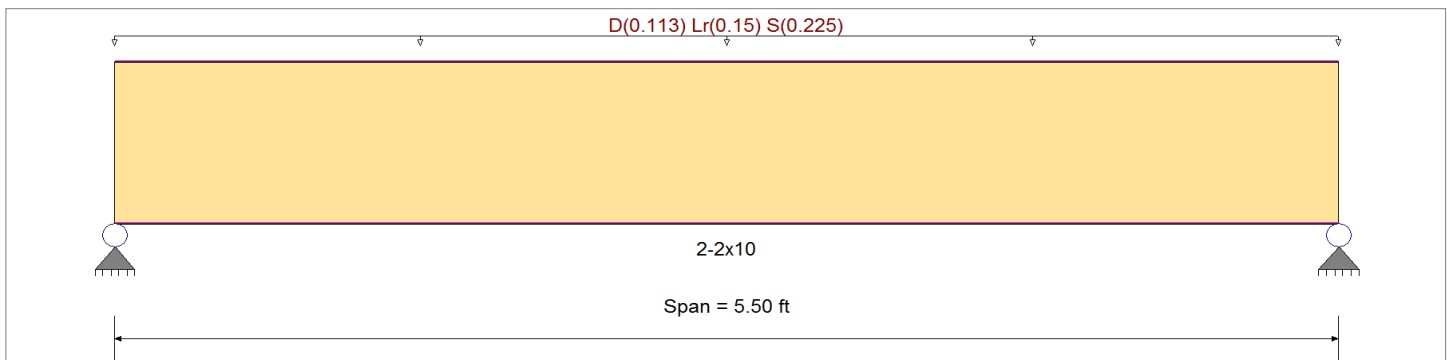

Applied Loads

Service loads entered. Load Factors will be applied for calculations.

Beam self weight calculated and added to loads

Uniform Load : D = 0.1130, Lr = 0.150, S = 0.2250, Tributary Width = 1.0 ft

DESIGN SUMMARY

Design OK

Maximum Bending Stress Ratio	=	0.320	1	Maximum Shear Stress Ratio	=	0.179	: 1
Section used for this span		2-2x10		Section used for this span		2-2x10	
fb: Actual	=	364.87 psi		fv: Actual	=	36.95 psi	
Fb: Allowable	=	1,138.50 psi		Fv: Allowable	=	207.00 psi	
Load Combination		+D+S		Load Combination		+D+S	
Location of maximum on span	=	2.750ft		Location of maximum on span	=	4.737 ft	
Span # where maximum occurs	=	Span # 1		Span # where maximum occurs	=	Span # 1	
Maximum Deflection							
Max Downward Transient Deflection		0.015 in	Ratio =	4484	>=	360	
Max Upward Transient Deflection		0.000 in	Ratio =	0	<	360	
Max Downward Total Deflection		0.023 in	Ratio =	2932	>=	240	
Max Upward Total Deflection		0.000 in	Ratio =	0	<	240	

Maximum Forces & Stresses for Load Combinations

Load Combination	Segment Length	Span #	Max Stress Ratios									Moment Values			Shear Values						
			M	V	C _d	C _{F/V}	C _i	C _r	C _m	C _t	C _L	M	fb	F'b	V	fv	F'v				
D Only	Length = 5.50 ft	1	0.142	0.079	0.90	1.100	1.00	1.00	1.00	1.00	1.00	1.00	0.45	126.23	891.00	0.00	0.00	0.00	0.24	12.78	162.00
+D+Lr	Length = 5.50 ft	1				1.100	1.00	1.00	1.00	1.00	1.00	1.00	1.02	285.32	1237.50	0.00	0.00	0.00	0.00	0.00	225.00
+D+S	Length = 5.50 ft	1	0.320	0.179	1.15	1.100	1.00	1.00	1.00	1.00	1.00	1.00	1.30	364.87	1138.50	0.00	0.00	0.00	0.68	36.95	207.00
+D+0.750Lr	Length = 5.50 ft	1				1.100	1.00	1.00	1.00	1.00	1.00	1.00	0.88	245.55	1237.50	0.00	0.00	0.00	0.00	0.00	0.00
+D+0.750S	Length = 5.50 ft	1	0.198	0.111	1.25	1.100	1.00	1.00	1.00	1.00	1.00	1.00	1.09	305.21	1138.50	0.00	0.00	0.00	0.57	30.91	207.00
+0.60D	Length = 5.50 ft	1				1.100	1.00	1.00	1.00	1.00	1.00	1.00	0.27	75.74	1584.00	0.00	0.00	0.00	0.14	7.67	288.00



Project Title: Mercer Island Custom Home
 Engineer: KJH
 Project ID: 21-045
 Project Descr: Framing and Foundations

Printed: 9 AUG 2021, 12:29AM

Wood Beam

Software copyright ENERCALC, INC. 1983-2020, Build:12.20.8.24

Lic. # : KW-06011847

Merrell Design Services PLLC

DESCRIPTIO Beam 1

Overall Maximum Deflections

Load Combination	Span	Max. "-" Defl	Location in Span	Load Combination	Max. "+" Defl	Location in Span
+D+S	1	0.0225	2.770		0.0000	0.000

Vertical Reactions

Support notation : Far left is #'

Values in KIPS

Load Combination	Support 1	Support 2
Overall MAXimum	0.946	0.946
Overall MINimum	0.619	0.619
D Only	0.327	0.327
+D+Lr	0.740	0.740
+D+S	0.946	0.946
+D+0.750Lr	0.637	0.637
+D+0.750S	0.791	0.791
+0.60D	0.196	0.196
Lr Only	0.413	0.413
S Only	0.619	0.619



Wood Beam

Software copyright ENERCALC, INC. 1983-2020, Build:12.20.8.24
 Merrell Design Services PLLC

Lic. #: KW-06011847

DESCRIPTION Beam 2

CODE REFERENCES

Calculations per NDS 2015, IBC 2015, CBC 2016, ASCE 7-10
 Load Combination Set : ASCE 7-10

Material Properties

Analysis Method	Allowable Stress Design	Fb +	900.0 psi	E : Modulus of Elasticity	
Load Combination	ASCE 7-10	Fb -	900.0 psi	Ebend- xx	1,600.0ksi
		Fc - Prll	1,350.0 psi	Eminbend - x	580.0ksi
Wood Species	Douglas Fir-Larch	Fc - Perp	625.0 psi		
Wood Grade	No.2	Fv	180.0 psi		
		Ft	575.0 psi	Density	31.210pcf
Beam Bracing	Beam is Fully Braced against lateral-torsional buckling				

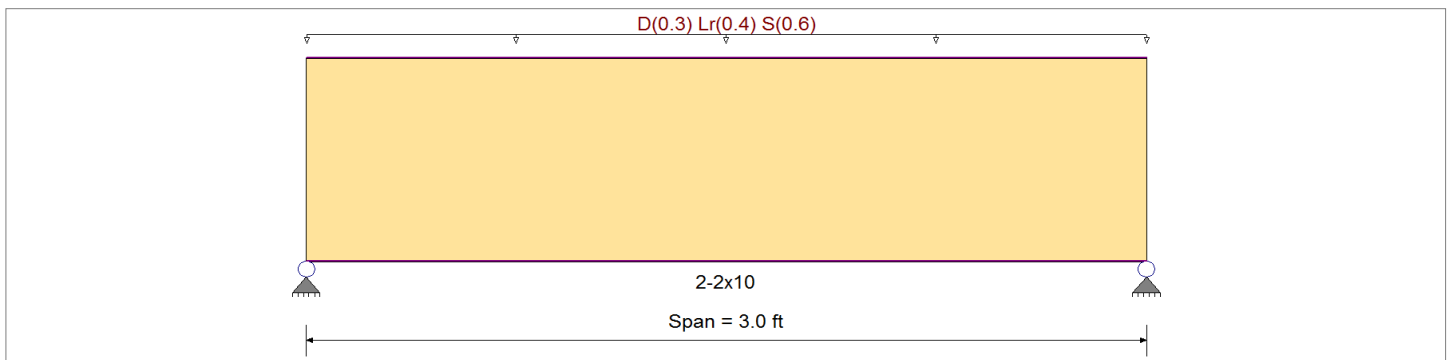

Applied Loads

Service loads entered. Load Factors will be applied for calculations.

Beam self weight calculated and added to loads
 Uniform Load : D = 0.30, Lr = 0.40, S = 0.60, Tributary Width = 1.0 ft

DESIGN SUMMARY

Design OK

Maximum Bending Stress Ratio	=	0.251 : 1	Maximum Shear Stress Ratio	=	0.174 : 1
Section used for this span		2-2x10	Section used for this span		2-2x10
fb: Actual	=	285.90psi	fv: Actual	=	35.93 psi
Fb: Allowable	=	1,138.50psi	Fv: Allowable	=	207.00 psi
Load Combination		+D+S	Load Combination		+D+S
Location of maximum on span	=	1.500ft	Location of maximum on span	=	0.000ft
Span # where maximum occurs	=	Span # 1	Span # where maximum occurs	=	Span # 1
Maximum Deflection					
Max Downward Transient Deflection		0.003 in	Ratio =	10361	>=360
Max Upward Transient Deflection		0.000 in	Ratio =	0	<360
Max Downward Total Deflection		0.005 in	Ratio =	6862	>=240
Max Upward Total Deflection		0.000 in	Ratio =	0	<240

Maximum Forces & Stresses for Load Combinations

Load Combination	Segment Length	Span #	Max Stress Ratios									Moment Values			Shear Values							
			M	V	C _d	C _{F/V}	C _i	C _r	C _m	C _t	C _L	M	fb	F'b	V	fv	F'v					
D Only	Length = 3.0 ft	1	0.108	0.075	0.90	1.100	1.00	1.00	1.00	1.00	1.00	1.00	1.00	0.34	96.57	891.00	0.00	0.00	0.00	0.22	12.13	162.00
+D+Lr	Length = 3.0 ft	1				1.100	1.00	1.00	1.00	1.00	1.00	1.00	1.00	0.79	222.79	1237.50	0.00	0.00	0.00	0.00	0.00	225.00
+D+S	Length = 3.0 ft	1	0.251	0.174	1.15	1.100	1.00	1.00	1.00	1.00	1.00	1.00	1.00	1.02	285.90	1138.50	0.00	0.00	0.00	0.66	35.93	207.00
+D+0.750Lr	Length = 3.0 ft	1				1.100	1.00	1.00	1.00	1.00	1.00	1.00	1.00	0.68	191.23	1237.50	0.00	0.00	0.00	0.00	0.00	225.00
+D+0.750S	Length = 3.0 ft	1	0.155	0.107	1.25	1.100	1.00	1.00	1.00	1.00	1.00	1.00	1.00	0.85	238.57	1138.50	0.00	0.00	0.00	0.55	29.98	207.00
+0.60D	Length = 3.0 ft	1	0.037	0.025	1.60	1.100	1.00	1.00	1.00	1.00	1.00	1.00	1.00	0.21	57.94	1584.00	0.00	0.00	0.00	0.13	7.28	288.00



Project Title: Mercer Island Custom Home
 Engineer: KJH
 Project ID: 21-045
 Project Descr: Framing and Foundations

Printed: 9 AUG 2021, 12:29AM

Wood Beam

Software copyright ENERCALC, INC. 1983-2020, Build:12.20.8.24

Lic. # : KW-06011847

Merrell Design Services PLLC

DESCRIPTIO Beam 2

Overall Maximum Deflections

Load Combination	Span	Max. "-" Defl	Location in Span	Load Combination	Max. "+" Defl	Location in Span
+D+S	1	0.0052	1.511		0.0000	0.000

Vertical Reactions

Load Combination	Support notation : Far left is #'		Values in KIPS	
	Support 1	Support 2		
Overall MAXimum	1.359	1.359		
Overall MINimum	0.900	0.900		
D Only	0.459	0.459		
+D+Lr	1.059	1.059		
+D+S	1.359	1.359		
+D+0.750Lr	0.909	0.909		
+D+0.750S	1.134	1.134		
+0.60D	0.275	0.275		
Lr Only	0.600	0.600		
S Only	0.900	0.900		



Wood Beam

Software copyright ENERCALC, INC. 1983-2020, Build:12.20.8.24
 Merrell Design Services PLLC

Lic. #: KW-06011847

DESCRIPTION Beam 3

CODE REFERENCES

Calculations per NDS 2015, IBC 2015, CBC 2016, ASCE 7-10
 Load Combination Set : ASCE 7-10

Material Properties

Analysis Method	Allowable Stress Design	Fb +	2,400.0 psi	E : Modulus of Elasticity	
Load Combination	ASCE 7-10	Fb -	2,400.0 psi	Ebend- xx	1,800.0ksi
Wood Species	DF/DF	Fc - Prll	1,650.0 psi	Eminbend - x	950.0ksi
Wood Grade	24F-V8	Fc - Perp	650.0 psi	Ebend- yy	1,600.0ksi
		Fv	265.0 psi	Eminbend - y	850.0ksi
		Ft	1,100.0 psi	Density	31.210pcf
Beam Bracing	Beam is Fully Braced against lateral-torsional buckling				

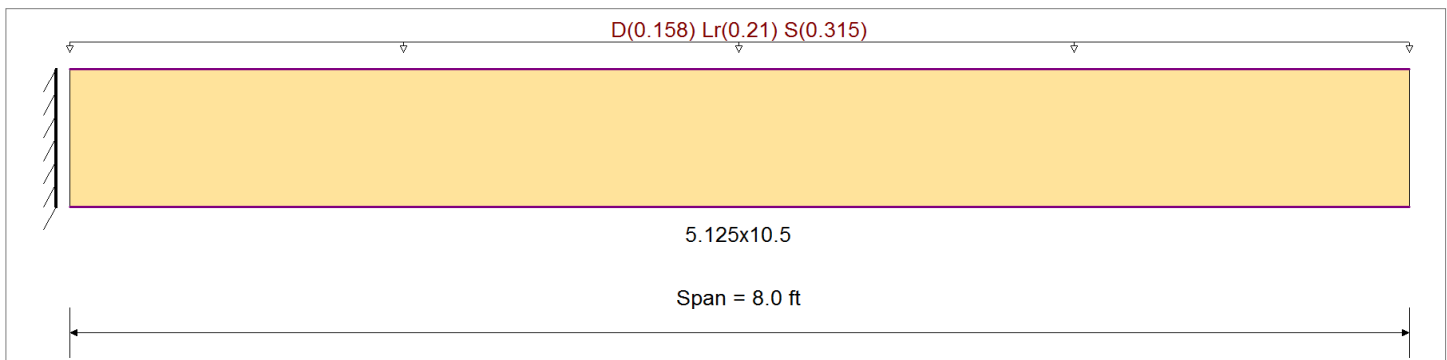

Applied Loads

Service loads entered. Load Factors will be applied for calculations.

Beam self weight calculated and added to loads

Uniform Load : D = 0.1580, Lr = 0.210, S = 0.3150, Tributary Width = 1.0 ft

DESIGN SUMMARY

Design OK

Maximum Bending Stress Ratio	=	0.716	1	Maximum Shear Stress Ratio	=	0.317	: 1
Section used for this span		5.125x10.5		Section used for this span		5.125x10.5	
fb: Actual	=	1,976.29psi		fv: Actual	=	96.64 psi	
Fb: Allowable	=	2,760.00psi		Fv: Allowable	=	304.75 psi	
Load Combination		+D+S		Load Combination		+D+S	
Location of maximum on span	=	0.000 ft		Location of maximum on span	=	0.000 ft	
Span # where maximum occurs	=	Span # 1		Span # where maximum occurs	=	Span # 1	
Maximum Deflection							
Max Downward Transient Deflection		0.312 in	Ratio =	614	>=	360	
Max Upward Transient Deflection		0.000 in	Ratio =	0	<	360	
Max Downward Total Deflection		0.481 in	Ratio =	398	>=	240	
Max Upward Total Deflection		0.000 in	Ratio =	0	<	240	

Maximum Forces & Stresses for Load Combinations

Load Combination	Segment Length	Span #	Max Stress Ratios									Moment Values			Shear Values							
			M	V	C _d	C _{F/V}	C _i	C _r	C _m	C _t	C _L	M	fb	F'b	V	fv	F'v					
D Only	Length = 8.0 ft	1	0.320	0.142	0.90	1.000	1.00	1.00	1.00	1.00	1.00	1.00	1.00	5.43	691.83	2160.00	0.00	0.00	0.00	1.21	33.83	238.50
+D+Lr	Length = 8.0 ft	1	0.516	0.229	1.25	1.000	1.00	1.00	1.00	1.00	1.00	1.00	1.00	12.15	1,548.13	3000.00	0.00	0.00	0.00	0.00	0.00	0.00
+D+S	Length = 8.0 ft	1	0.716	0.317	1.15	1.000	1.00	1.00	1.00	1.00	1.00	1.00	1.00	15.51	1,976.29	2760.00	0.00	0.00	0.00	3.47	96.64	304.75
+D+0.750Lr	Length = 8.0 ft	1	0.445	0.197	1.25	1.000	1.00	1.00	1.00	1.00	1.00	1.00	1.00	10.47	1,334.06	3000.00	0.00	0.00	0.00	0.00	0.00	0.00
+D+0.750S	Length = 8.0 ft	1	0.600	0.266	1.15	1.000	1.00	1.00	1.00	1.00	1.00	1.00	1.00	12.99	1,655.17	2760.00	0.00	0.00	0.00	2.90	80.94	304.75
+0.60D	Length = 8.0 ft	1	0.108	0.048	1.60	1.000	1.00	1.00	1.00	1.00	1.00	1.00	1.00	3.26	415.10	3840.00	0.00	0.00	0.00	0.73	20.30	424.00



Project Title: Mercer Island Custom Home
 Engineer: KJH
 Project ID: 21-045
 Project Descr: Framing and Foundations

Printed: 9 AUG 2021, 12:29AM

Wood Beam

Software copyright ENERCALC, INC. 1983-2020, Build:12.20.8.24

Lic. # : KW-06011847

Merrell Design Services PLLC

DESCRIPTIO Beam 3

Overall Maximum Deflections

Load Combination	Span	Max. "-" Defl	Location in Span	Load Combination	Max. "+" Defl	Location in Span
+D+S	1	0.4807	8.000		0.0000	0.000

Vertical Reactions

Load Combination	Support notation : Far left is #'		Values in KIPS
	Support 1	Support 2	
Overall MAXimum	3.877		
Overall MINimum	2.520		
D Only	1.357		
+D+Lr	3.037		
+D+S	3.877		
+D+0.750Lr	2.617		
+D+0.750S	3.247		
+0.60D	0.814		
Lr Only	1.680		
S Only	2.520		



Wood Beam

Software copyright ENERCALC, INC. 1983-2020, Build:12.20.8.24
 Merrell Design Services PLLC

Lic. #: KW-06011847

DESCRIPTIO Beam 4

CODE REFERENCES

Calculations per NDS 2015, IBC 2015, CBC 2016, ASCE 7-10
 Load Combination Set : ASCE 7-10

Material Properties

Analysis Method	Allowable Stress Design	Fb +	2400 psi	E : Modulus of Elasti	
Load Combination	ASCE 7-10	Fb -	1850 psi	Ebend- xx	1800ksi
Wood Species	DF/DF	Fc - Prll	1650 psi	Eminbend - x	950ksi
Wood Grade	24F-V4	Fc - Perp	650 psi	Ebend- yy	1600ksi
		Fv	265 psi	Eminbend - y	850ksi
		Ft	1100 psi	Density	31.21 pcf

Beam Bracing Beam is Fully Braced against lateral-torsional buckling

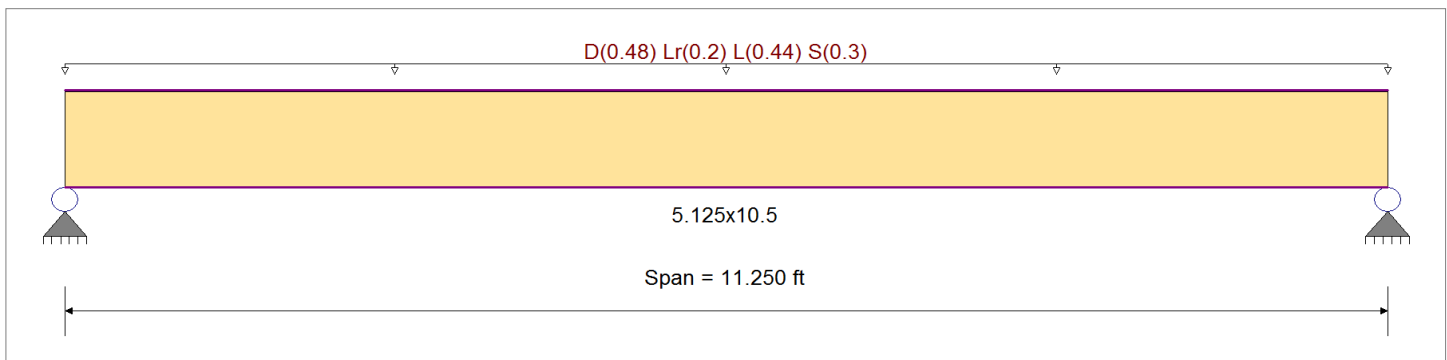

Applied Loads

Service loads entered. Load Factors will be applied for calculations.

Uniform Load : D = 0.480, Lr = 0.20, L = 0.440, S = 0.30, Tributary Width = 1.0 ft

DESIGN SUMMARY

Design OK

Maximum Bending Stress Ratio =	0.773 < 1	Maximum Shear Stress Ratio =	0.461 < 1
Section used for this span	5.125x10.5	Section used for this span	5.125x10.5
fb: Actual =	1,854.65 psi	fv: Actual =	122.14 psi
Fb: Allowable =	2,400.00 psi	Fv: Allowable =	265.00 psi
Load Combination	+D+L	Load Combination	+D+L
Location of maximum on span =	5.625 ft	Location of maximum on span =	10.388 ft
Span # where maximum occurs =	Span # 1	Span # where maximum occurs =	Span # 1
Maximum Deflection			
Max Downward Transient Deflection	0.179 in	Ratio =	753 >= 360
Max Upward Transient Deflection	0.000 in	Ratio =	0 < 360
Max Downward Total Deflection	0.422 in	Ratio =	320 >= 240
Max Upward Total Deflection	0.000 in	Ratio =	0 < 240

Maximum Forces & Stresses for Load Combinations

Load Combination	Segment Length	Span #	Max Stress Ratios									Moment Values			Shear Values						
			M	V	C _d	C _{F/V}	C _i	C _r	C _m	C _t	C _L	M	fb	F'b	V	fv	F'v				
D Only	Length = 11.250 ft	1	0.448	0.267	0.90	1.000	1.00	1.00	1.00	1.00	1.00	1.00	1.00	1.00	7.59	967.65	2160.00	0.00	0.00	0.00	0.00
+D+L	Length = 11.250 ft	1	0.773	0.461	1.00	1.000	1.00	1.00	1.00	1.00	1.00	1.00	1.00	1.00	14.55	1,854.65	2400.00	0.00	0.00	0.00	0.00
+D+Lr	Length = 11.250 ft	1	0.457	0.273	1.25	1.000	1.00	1.00	1.00	1.00	1.00	1.00	1.00	1.00	10.76	1,370.83	3000.00	0.00	0.00	0.00	0.00
+D+S	Length = 11.250 ft	1	0.570	0.340	1.15	1.000	1.00	1.00	1.00	1.00	1.00	1.00	1.00	1.00	12.34	1,572.42	2760.00	0.00	0.00	0.00	0.00
+D+0.750Lr+0.750L	Length = 11.250 ft	1	0.645	0.385	1.25	1.000	1.00	1.00	1.00	1.00	1.00	1.00	1.00	1.00	15.19	1,935.29	3000.00	0.00	0.00	0.00	0.00
+D+0.750L+0.750S	Length = 11.250 ft	1	0.756	0.451	1.15	1.000	1.00	1.00	1.00	1.00	1.00	1.00	1.00	1.00	16.37	2,086.49	2760.00	0.00	0.00	0.00	0.00
+0.60D	Length = 11.250 ft	1	0.151	0.090	1.60	1.000	1.00	1.00	1.00	1.00	1.00	1.00	1.00	1.00	4.56	580.59	3840.00	0.00	0.00	0.00	0.00



Project Title: Mercer Island Custom Home
 Engineer: KJH
 Project ID: 21-045
 Project Descr: Framing and Foundations

Printed: 9 AUG 2021, 12:29AM

Wood Beam

Software copyright ENERCALC, INC. 1983-2020, Build:12.20.8.24

Lic. # : KW-06011847

Merrell Design Services PLLC

DESCRIPTIO Beam 4

Overall Maximum Deflections

Load Combination	Span	Max. "-" Defl	Location in Span	Load Combination	Max. "+" Defl	Location in Span
+D+0.750L+0.750S	1	0.4216	5.666		0.0000	0.000

Vertical Reactions

Load Combination	Support notation : Far left is #'		Values in KIPS	
	Support 1	Support 2		
Overall MAXimum	5.822	5.822		
Overall MINimum	1.688	1.688		
D Only	2.700	2.700		
+D+L	5.175	5.175		
+D+Lr	3.825	3.825		
+D+S	4.388	4.388		
+D+0.750Lr+0.750L	5.400	5.400		
+D+0.750L+0.750S	5.822	5.822		
+0.60D	1.620	1.620		
Lr Only	1.125	1.125		
L Only	2.475	2.475		
S Only	1.688	1.688		



Wood Beam

Software copyright ENERCALC, INC. 1983-2020, Build:12.20.8.24

Lic. #: KW-06011847

Merrell Design Services PLLC

DESCRIPTIO Beam 5

CODE REFERENCES

Calculations per NDS 2015, IBC 2015, CBC 2016, ASCE 7-10
 Load Combination Set : ASCE 7-10

Material Properties

Analysis Method	Allowable Stress Design	Fb +	900.0 psi	E : Modulus of Elasti	
Load Combinati	ASCE 7-10	Fb -	900.0 psi	Ebend- xx	1,600.0ksi
		Fc - Prll	1,350.0 psi	Eminbend - x	580.0ksi
Wood Species	Douglas Fir-Larch	Fc - Perp	625.0 psi		
Wood Grade	No.2	Fv	180.0 psi		
		Ft	575.0 psi	Density	31.210pcf
Beam Bracing	Beam is Fully Braced against lateral-torsional buckling				

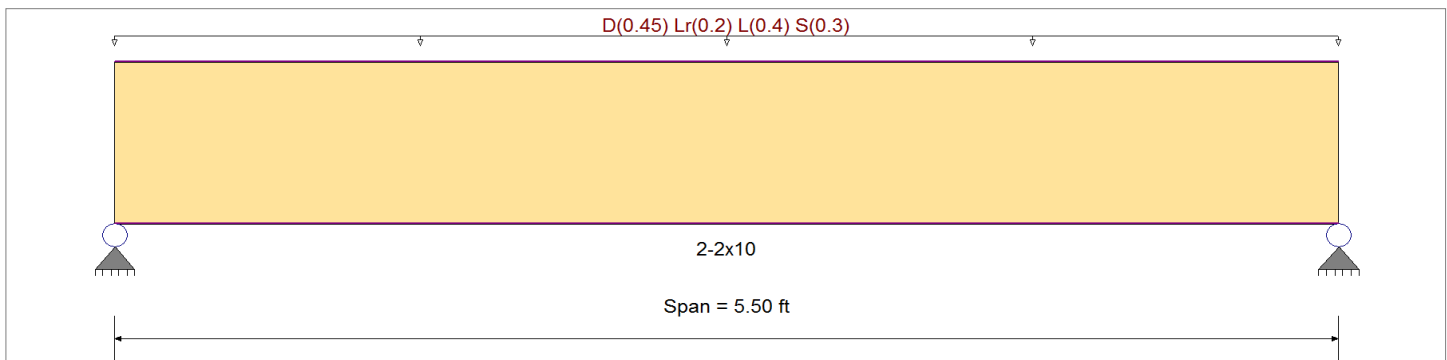

Applied Loads

Service loads entered. Load Factors will be applied for calculations.

Beam self weight calculated and added to loads

Uniform Load : D = 0.450, Lr = 0.20, L = 0.40, S = 0.30, Tributary Width = 1.0 ft

DESIGN SUMMARY

Design OK

Maximum Bending Stress Ratio	=	0.917 : 1	Maximum Shear Stress Ratio	=	0.511 : 1
Section used for this span		2-2x10	Section used for this span		2-2x10
fb: Actual	=	907.91 psi	fv: Actual	=	91.95 psi
Fb: Allowable	=	990.00 psi	Fv: Allowable	=	180.00 psi
Load Combination		+D+L	Load Combination		+D+L
Location of maximum on span	=	2.750ft	Location of maximum on span	=	4.737 ft
Span # where maximum occurs	=	Span # 1	Span # where maximum occurs	=	Span # 1
Maximum Deflection					
Max Downward Transient Deflection		0.026 in	Ratio =		2522 >=360
Max Upward Transient Deflection		0.000 in	Ratio =		0 <360
Max Downward Total Deflection		0.064 in	Ratio =		1028 >=240
Max Upward Total Deflection		0.000 in	Ratio =		0 <240

Maximum Forces & Stresses for Load Combinations

Load Combination	Segment Length	Span #	Max Stress Ratios									Moment Values			Shear Values								
			M	V	C _d	C _{F/V}	C _i	C _r	C _m	C _t	C _L	M	fb	F'b	V	fv	F'v						
D Only	Length = 5.50 ft	1	0.543	0.302	0.90	1.100	1.00	1.00	1.00	1.00	1.00	1.00	1.00	1.72	483.66	891.00	0.00	0.00	0.00	0.00	0.00	162.00	
+D+L	Length = 5.50 ft	1	0.917	0.511	1.00	1.100	1.00	1.00	1.00	1.00	1.00	1.00	1.00	3.24	907.91	990.00	0.00	0.00	0.00	0.00	0.00	0.00	180.00
+D+Lr	Length = 5.50 ft	1	0.562	0.313	1.25	1.100	1.00	1.00	1.00	1.00	1.00	1.00	1.00	2.48	695.79	1237.50	0.00	0.00	0.00	0.00	0.00	0.00	225.00
+D+S	Length = 5.50 ft	1	0.704	0.392	1.15	1.100	1.00	1.00	1.00	1.00	1.00	1.00	1.00	2.86	801.85	1138.50	0.00	0.00	0.00	0.00	0.00	0.00	207.00
+D+0.750Lr+0.750L	Length = 5.50 ft	1	0.777	0.433	1.25	1.100	1.00	1.00	1.00	1.00	1.00	1.00	1.00	3.43	960.94	1237.50	0.00	0.00	0.00	0.00	0.00	0.00	225.00
+D+0.750L+0.750S	Length = 5.50 ft	1	0.914	0.509	1.15	1.100	1.00	1.00	1.00	1.00	1.00	1.00	1.00	3.71	1,040.49	1138.50	0.00	0.00	0.00	0.00	0.00	0.00	207.00
+0.60D						1.100	1.00	1.00	1.00	1.00	1.00	1.00	1.00			0.00	0.00	0.00	0.00	0.00	0.00	0.00	0.00



Project Title: Mercer Island Custom Home
 Engineer: KJH
 Project ID: 21-045
 Project Descr: Framing and Foundations

Printed: 9 AUG 2021, 12:29AM

Wood Beam

Software copyright ENERCALC, INC. 1983-2020, Build:12.20.8.24

Lic. # : KW-06011847

Merrell Design Services PLLC

DESCRIPTIO Beam 5

Load Combination	Segment Length	Span #	Max Stress Ratios									Moment Values			Shear Values		
			M	V	C _d	C _{F/V}	C _i	C _r	C _m	C _t	C _L	M	fb	F'b	V	fv	Fv
	Length = 5.50 ft	1	0.183	0.102	1.60	1.100	1.00	1.00	1.00	1.00	1.00	1.03	290.20	1584.00	0.54	29.39	288.00

Overall Maximum Deflections

Load Combination	Span	Max. "-" Defl	Location in Span	Load Combination	Max. "+" Defl	Location in Span
+D+0.750L+0.750S	1	0.0642	2.770		0.0000	0.000

Vertical Reactions

Load Combination	Support notation : Far left is #'		Values in KIPS	
	Support 1	Support 2		
Overall MAXimum	2.698	2.698		
Overall MINimum	0.825	0.825		
D Only	1.254	1.254		
+D+L	2.354	2.354		
+D+Lr	1.804	1.804		
+D+S	2.079	2.079		
+D+0.750Lr+0.750L	2.492	2.492		
+D+0.750L+0.750S	2.698	2.698		
+0.60D	0.752	0.752		
Lr Only	0.550	0.550		
L Only	1.100	1.100		
S Only	0.825	0.825		



Wood Beam

Software copyright ENERCALC, INC. 1983-2020, Build:12.20.8.24
 Merrell Design Services PLLC

Lic. #: KW-06011847

DESCRIPTION Beam 6

CODE REFERENCES

Calculations per NDS 2015, IBC 2015, CBC 2016, ASCE 7-10
 Load Combination Set : ASCE 7-10

Material Properties

Analysis Method	Allowable Stress Design	Fb +	2,400.0 psi	E : Modulus of Elasticity	
Load Combination	ASCE 7-10	Fb -	1,850.0 psi	Ebend- xx	1,800.0ksi
Wood Species	DF/DF	Fc - Prll	1,650.0 psi	Eminbend - x	950.0ksi
Wood Grade	24F-V4	Fc - Perp	650.0 psi	Ebend- yy	1,600.0ksi
		Fv	265.0 psi	Eminbend - y	850.0ksi
		Ft	1,100.0 psi	Density	31.210pcf
Beam Bracing	Beam is Fully Braced against lateral-torsional buckling				

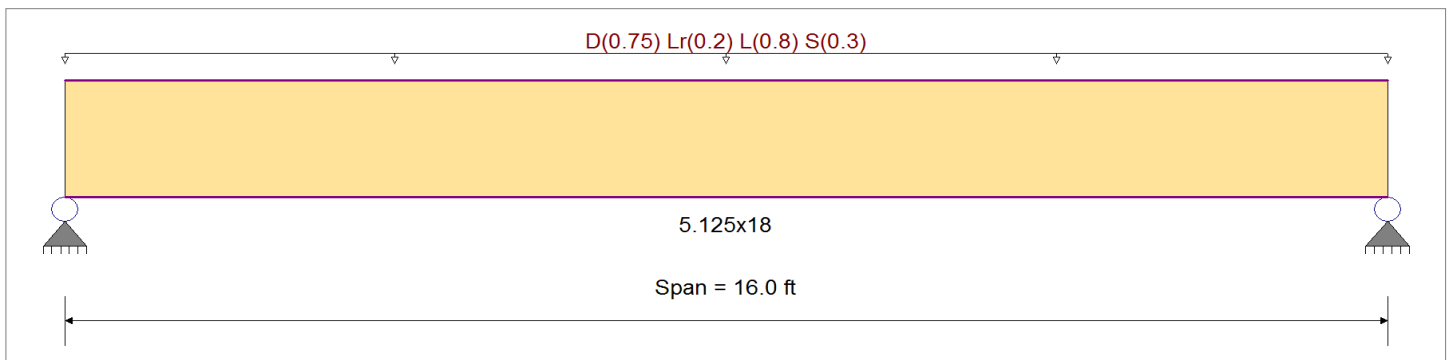

Applied Loads

Service loads entered. Load Factors will be applied for calculations.

Beam self weight calculated and added to loads

Uniform Load : D = 0.750, Lr = 0.20, L = 0.80, S = 0.30, Tributary Width = 1.0 ft

DESIGN SUMMARY

Design OK

Maximum Bending Stress Ratio	=	0.920 < 1	Maximum Shear Stress Ratio	=	0.630 < 1
Section used for this span	=	5.125x18	Section used for this span	=	5.125x18
fb: Actual	=	2,178.42psi	fv: Actual	=	166.96 psi
Fb: Allowable	=	2,368.17psi	Fv: Allowable	=	265.00 psi
Load Combination	=	+D+L	Load Combination	=	+D+L
Location of maximum on span	=	8.000ft	Location of maximum on span	=	14.540ft
Span # where maximum occurs	=	Span # 1	Span # where maximum occurs	=	Span # 1
Maximum Deflection					
Max Downward Transient Deflection		0.265 in	Ratio =		725 >= 360
Max Upward Transient Deflection		0.000 in	Ratio =		0 < 360
Max Downward Total Deflection		0.528 in	Ratio =		363 >= 240
Max Upward Total Deflection		0.000 in	Ratio =		0 < 240

Maximum Forces & Stresses for Load Combinations

Load Combination	Segment Length	Span #	Max Stress Ratios										Moment Values			Shear Values									
			M	V	C _d	C _{F/V}	C _i	C _r	C _m	C _t	C _L	M	fb	F'b	V	fv	F'v								
D Only	Length = 16.0 ft	1	0.501	0.343	0.90	0.987	1.00	1.00	1.00	1.00	1.00	1.00	1.00	1.00	1.00	1.00	1.00	1.00	0.00	0.00	0.00	0.00	0.00	0.00	0.00
+D+L	Length = 16.0 ft	1	0.920	0.630	1.00	0.987	1.00	1.00	1.00	1.00	1.00	1.00	1.00	1.00	1.00	1.00	1.00	1.00	0.00	0.00	0.00	0.00	0.00	0.00	0.00
+D+Lr	Length = 16.0 ft	1	0.455	0.311	1.25	0.987	1.00	1.00	1.00	1.00	1.00	1.00	1.00	1.00	1.00	1.00	1.00	1.00	0.00	0.00	0.00	0.00	0.00	0.00	0.00
+D+S	Length = 16.0 ft	1	0.545	0.373	1.15	0.987	1.00	1.00	1.00	1.00	1.00	1.00	1.00	1.00	1.00	1.00	1.00	1.00	0.00	0.00	0.00	0.00	0.00	0.00	0.00
+D+0.750Lr+0.750L	Length = 16.0 ft	1	0.712	0.488	1.25	0.987	1.00	1.00	1.00	1.00	1.00	1.00	1.00	1.00	1.00	1.00	1.00	1.00	0.00	0.00	0.00	0.00	0.00	0.00	0.00
+D+0.750L+0.750S	Length = 16.0 ft	1	0.813	0.557	1.15	0.987	1.00	1.00	1.00	1.00	1.00	1.00	1.00	1.00	1.00	1.00	1.00	1.00	0.00	0.00	0.00	0.00	0.00	0.00	0.00
+0.60D						0.987	1.00	1.00	1.00	1.00	1.00	1.00	1.00	1.00	1.00	1.00	1.00	1.00	0.00	0.00	0.00	0.00	0.00	0.00	0.00



Project Title: Mercer Island Custom Home
 Engineer: KJH
 Project ID: 21-045
 Project Descr: Framing and Foundations

Printed: 9 AUG 2021, 12:29AM

Wood Beam

Software copyright ENERCALC, INC. 1983-2020, Build:12.20.8.24

Lic. # : KW-06011847

Merrell Design Services PLLC

DESCRIPTIO Beam 6

Load Combination	Segment Length	Span #	Max Stress Ratios									Moment Values			Shear Values		
			M	V	C _d	C _{F/V}	C _i	C _r	C _m	C _t	C _L	M	fb	F'b	V	fv	Fv
	Length = 16.0 ft	1	0.169	0.116	1.60	0.987	1.00	1.00	1.00	1.00	1.00	14.78	641.04	3789.06	3.02	49.13	424.00

Overall Maximum Deflections

Load Combination	Span	Max. "-" Defl	Location in Span	Load Combination	Max. "+" Defl	Location in Span
+D+0.750L+0.750S	1	0.5277	8.058		0.0000	0.000

Vertical Reactions

Load Combination	Support notation : Far left is #'		Values in KIPS	
	Support 1	Support 2		
Overall MAXimum	12.760	12.760		
Overall MINimum	2.400	2.400		
D Only	6.160	6.160		
+D+L	12.560	12.560		
+D+Lr	7.760	7.760		
+D+S	8.560	8.560		
+D+0.750Lr+0.750L	12.160	12.160		
+D+0.750L+0.750S	12.760	12.760		
+0.60D	3.696	3.696		
Lr Only	1.600	1.600		
L Only	6.400	6.400		
S Only	2.400	2.400		



Wood Beam

Software copyright ENERCALC, INC. 1983-2020, Build:12.20.8.24
 Merrell Design Services PLLC

Lic. #: KW-06011847

DESCRIPTION Beam 7

CODE REFERENCES

Calculations per NDS 2015, IBC 2015, CBC 2016, ASCE 7-10
 Load Combination Set : ASCE 7-10

Material Properties

Analysis Method	Allowable Stress Design	Fb +	900 psi	E : Modulus of Elasticity	
Load Combination	ASCE 7-10	Fb -	900 psi	Ebend- xx	1600ksi
		Fc - Prll	1350 psi	Eminbend - x	580ksi
Wood Species	Douglas Fir-Larch	Fc - Perp	625 psi		
Wood Grade	No.2	Fv	180 psi		
		Ft	575 psi	Density	31.21 pcf
Beam Bracing	Beam is Fully Braced against lateral-torsional buckling				

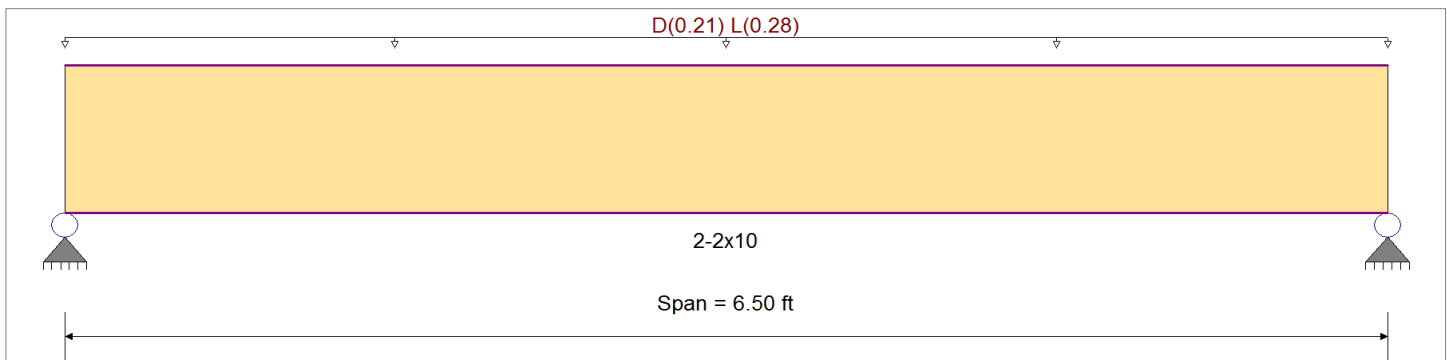

Applied Loads

Service loads entered. Load Factors will be applied for calculations.

Beam self weight calculated and added to loads
 Uniform Load : D = 0.210, L = 0.280, Tributary Width = 1.0 ft

DESIGN SUMMARY

Design OK

Maximum Bending Stress Ratio	=	0.742	1	Maximum Shear Stress Ratio	=	0.371	: 1
Section used for this span		2-2x10		Section used for this span		2-2x10	
fb: Actual	=	734.78	psi	fv: Actual	=	66.78	psi
Fb: Allowable	=	990.00	psi	Fv: Allowable	=	180.00	psi
Load Combination		+D+L		Load Combination		+D+L	
Location of maximum on span	=	3.250	ft	Location of maximum on span	=	5.741	ft
Span # where maximum occurs	=	Span # 1		Span # where maximum occurs	=	Span # 1	
Maximum Deflection							
Max Downward Transient Deflection		0.036	in	Ratio =	2183	>=360	
Max Upward Transient Deflection		0.000	in	Ratio =	0	<360	
Max Downward Total Deflection		0.063	in	Ratio =	1232	>=240	
Max Upward Total Deflection		0.000	in	Ratio =	0	<240	

Maximum Forces & Stresses for Load Combinations

Load Combination	Segment Length	Span #	Max Stress Ratios									Moment Values			Shear Values					
			M	V	C _d	C _{F/V}	C _i	C _r	C _m	C _t	C _L	M	fb	F'b	V	fv	F'v			
D Only	Length = 6.50 ft	1	0.359	0.180	0.90	1.100	1.00	1.00	1.00	1.00	1.00	1.14	320.00	891.00	0.00	0.00	0.00	0.00	0.00	162.00
+D+L	Length = 6.50 ft	1	0.742	0.371	1.00	1.100	1.00	1.00	1.00	1.00	1.00	2.62	734.78	990.00	0.00	0.00	0.00	0.00	0.00	180.00
+D+0.750L	Length = 6.50 ft	1	0.510	0.255	1.25	1.100	1.00	1.00	1.00	1.00	1.00	2.25	631.09	1237.50	0.00	0.00	0.00	0.00	0.00	225.00
+0.60D	Length = 6.50 ft	1	0.121	0.061	1.60	1.100	1.00	1.00	1.00	1.00	1.00	0.68	192.00	1584.00	0.00	0.00	0.00	0.00	0.00	288.00

Overall Maximum Deflections

Load Combination	Span	Max. "-" Defl	Location in Span	Load Combination	Max. "+" Defl	Location in Span
+D+L	1	0.0633	3.274		0.0000	0.000



Project Title: Mercer Island Custom Home
 Engineer: KJH
 Project ID: 21-045
 Project Descr: Framing and Foundations

Printed: 9 AUG 2021, 12:29AM

Wood Beam

Software copyright ENERCALC, INC. 1983-2020, Build:12.20.8.24

Lic. # : KW-06011847

Merrell Design Services PLLC

DESCRIPTIO Beam 7

Vertical Reactions

Support notation : Far left is #'

Values in KIPS

Load Combination	Support 1	Support 2
Overall MAXimum	1.612	1.612
Overall MINimum	0.910	0.910
D Only	0.702	0.702
+D+L	1.612	1.612
+D+0.750L	1.385	1.385
+0.60D	0.421	0.421
L Only	0.910	0.910



Wood Beam

Software copyright ENERCALC, INC. 1983-2020, Build:12.20.8.24
 Merrell Design Services PLLC

Lic. #: KW-06011847

DESCRIPTION Grid C second flr shear tfer beam

CODE REFERENCES

Calculations per NDS 2015, IBC 2015, CBC 2016, ASCE 7-10
 Load Combination Set : ASCE 7-10

Material Properties

Analysis Method	Allowable Stress Design	Fb +	2,400.0 psi	E : Modulus of Elasti	
Load Combination	ASCE 7-10	Fb -	2,400.0 psi	Ebend- xx	1,800.0ksi
Wood Species	DF/DF	Fc - Prll	1,650.0 psi	Eminbend - x	950.0ksi
Wood Grade	24F-V8	Fc - Perp	650.0 psi	Ebend- yy	1,600.0ksi
		Fv	265.0 psi	Eminbend - y	850.0ksi
		Ft	1,100.0 psi	Density	31.210pcf
Beam Bracing	Beam is Fully Braced against lateral-torsional buckling				

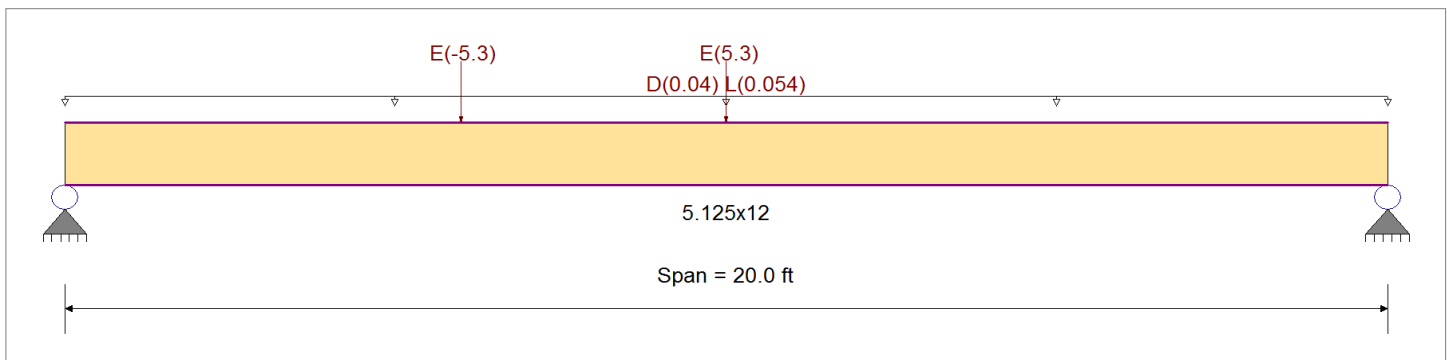

Applied Loads

Service loads entered. Load Factors will be applied for calculations.

Beam self weight calculated and added to loads
 Uniform Load : D = 0.040, L = 0.0540, Tributary Width = 1.0 ft
 Point Load : E = 5.30 k @ 10.0 ft
 Point Load : E = -5.30 k @ 6.0 ft

DESIGN SUMMARY

Design OK

Maximum Bending Stress Ratio	=	0.261 : 1	Maximum Shear Stress Ratio	=	0.183 : 1
Section used for this span		5.125x12	Section used for this span		5.125x12
fb: Actual	=	1,000.63psi	fv: Actual	=	77.52 psi
Fb: Allowable	=	3,840.00psi	Fv: Allowable	=	424.00 psi
Load Combination		+D+0.750L+0.5250E	Load Combination		+D+0.70E
Location of maximum on span	=	10.000ft	Location of maximum on span	=	6.058 ft
Span # where maximum occurs	=	Span # 1	Span # where maximum occurs	=	Span # 1
Maximum Deflection					
Max Downward Transient Deflection		0.258 in	Ratio =		930 >=360
Max Upward Transient Deflection		0.000 in	Ratio =		0 <360
Max Downward Total Deflection		0.387 in	Ratio =		620 >=240
Max Upward Total Deflection		0.000 in	Ratio =		0 <240

Maximum Forces & Stresses for Load Combinations

Load Combination	Segment Length	Span #	Max Stress Ratios								Moment Values			Shear Values								
			M	V	C _d	C _{F/V}	C _i	C _r	C _m	C _t	C _L	M	fb	F'b	V	fv	F'v					
D Only	Length = 20.0 ft	1	0.120	0.049	0.90	1.000	1.00	1.00	1.00	1.00	1.00	1.00	1.00	2.67	260.14	2160.00	0.00	0.00	0.00	0.48	11.77	238.50
+D+L	Length = 20.0 ft	1	0.218	0.089	1.00	1.000	1.00	1.00	1.00	1.00	1.00	1.00	1.00	5.37	523.56	2400.00	0.00	0.00	0.00	0.97	23.69	265.00
+D+0.750L	Length = 20.0 ft	1	0.153	0.063	1.25	1.000	1.00	1.00	1.00	1.00	1.00	1.00	1.00	4.69	457.70	3000.00	0.00	0.00	0.00	0.85	20.71	331.25
+D+0.70E	Length = 20.0 ft	1	0.256	0.183	1.60	1.000	1.00	1.00	1.00	1.00	1.00	1.00	1.00	10.09	984.05	3840.00	0.00	0.00	0.00	3.18	77.52	424.00
+D+0.750L+0.5250E	Length = 20.0 ft	1	0.261	0.149	1.60	1.000	1.00	1.00	1.00	1.00	1.00	1.00	1.00	10.26	1,000.63	3840.00	0.00	0.00	0.00	2.60	63.31	424.00
+0.60D						1.000	1.00	1.00	1.00	1.00	1.00	1.00	1.00			0.00	0.00	0.00	0.00	0.00	0.00	0.00



Project Title: Mercer Island Custom Home
 Engineer: KJH
 Project ID: 21-045
 Project Descr: Framing and Foundations

Printed: 9 AUG 2021, 12:29AM

Wood Beam

Software copyright ENERCALC, INC. 1983-2020, Build:12.20.8.24

Lic. #: KW-06011847

Merrell Design Services PLLC

DESCRIPTION Grid C second flr shear tfer beam

Load Combination	Segment Length	Span #	Max Stress Ratios									Moment Values			Shear Values		
			M	V	C _d	C _{F/V}	C _i	C _r	C _m	C _t	C _L	M	fb	F'b	V	fv	F'v
Length = 20.0 ft	1	0.041	0.017	1.60	1.000	1.00	1.00	1.00	1.00	1.00	1.60	156.09	3840.00	0.29	7.06	424.00	
+0.60D+0.70E					1.000	1.00	1.00	1.00	1.00	1.00			0.00	0.00	0.00	0.00	
Length = 20.0 ft	1	0.229	0.178	1.60	1.000	1.00	1.00	1.00	1.00	1.00	9.02	879.99	3840.00	3.09	75.47	424.00	

Overall Maximum Deflections

Load Combination	Span	Max. "-" Defl	Location in Span	Load Combination	Max. "+" Defl	Location in Span
+D+0.750L+0.5250E	1	0.3865	10.949		0.0000	0.000

Vertical Reactions

Support notation : Far left is #'

Values in KIPS

Load Combination	Support 1	Support 2
Overall MAXimum	1.073	1.495
Overall MINimum	0.540	1.060
D Only	0.533	0.533
+D+L	1.073	1.073
+D+0.750L	0.938	0.938
+D+0.70E	-0.209	1.275
+D+0.750L+0.5250E	0.382	1.495
+0.60D	0.320	0.320
+0.60D+0.70E	-0.422	1.062
L Only	0.540	0.540
E Only	-1.060	1.060

WIND EXPOSURE CATEGORIES & WIND SPEED-UP FACTORS (ICC Section 1609 & ASCE 7-05 Chapter 6)





It is the responsibility of the Owner (or their Design Professional) to review site conditions and determine the K_{zt} factor to be utilized for each specific project. The K_{zt} factors and wind exposure categories indicated on this map are the minimum values accepted by the City of Mercer Island without requiring the design professional to submit additional calculations and supporting topographic documentation (to verify the values utilized in their wind load determination).

Please note – The K_{zt} values indicated on this map are approximations based upon periodic calculations of representative samplings around Mercer Island. These values are intended for City of Mercer Island’s plan review purposes only.

WIND EXPOSURE CATEGORIES:

Wind Exposure Category		Exposure 'C' (1500 feet from Lake)
		Exposure 'B' (all other areas)

WIND SPEED-UP (TOPOGRAPHIC EFFECT) - K_{zt} Factor :

K_{zt} Factor		$K_{zt} = 1.0$
		$K_{zt} = 1.3$
		$K_{zt} = 1.6$
		$K_{zt} = 1.9$



Project Title: Mercer Island Custom Home
 Engineer: KJH
 Project ID: 21-045
 Project Descr: Framing and Foundations

Printed: 9 AUG 2021, 12:36AM

ASCE 7-16 Wind Forces Chpt 28, Pt2 & Chpt 30, Pt2

Software copyright ENERCALC, INC. 1983-2020, Build:12.20.8.24
 Merrell Design Services PLLC

Lic. #: KW-06011847

DESCRIPTIO Wind forces - Mercer Island

General Design Values

Calculations per ASCE 7-16

V : Basic Wind Speed per Sect 26.5-1 or 2 **110.0** mph
 User specified minimum design pressu **10.0** psf
 Occupancy per Table 1.5-1 **II** All Buildings and other structures except those listed
 Exposure Category per 26.7 **Exposure C**
 Topographic Factor Kzt per 26.8 **1.00**

Main Force Resisting System Valu

MRH : Mean Roof Height **30.0** ft
 Roof Slope Angle **0 to 5** degrees

Component & Cladding Values

Effective Wind Area of Component & Clad: **10.0** ft²
 Roof pitch for cladding pressu **Flat/Hip/Gable** Roof
 LHD : Least Horizontal Dimension **40.0** ft
 a = max (0.04 * LHD, 3, min(0.10 * LHD, 0.4*MRH)) **4.00** ft

Lambda MWFRS: per Figure 26. **1.40**

Lambda Component & Cladding : per Figure **1.40**

Design Wind Pressures

Horizontal Pressures . . .

Zone: A = 26.88 psf Zone: C = 17.78 psf
 Zone: B = -14.00 psf Zone: D = -10.00 psf

Vertical Pressures . . .

Zone: E = -32.34 psf Zone: G = -22.40 psf
 Zone: F = -18.34 psf Zone: H = -14.14 psf

Overhangs . . .

Zone: Eoh = -45.22 psf Zone: Goh = -35.42 psf

ASCE 7-16 Section 28.5.4 Minimum Design Wind Loads requires that the load effects of the design wind pressures from Section 28.5.3 shall not be less than a minimum load defined by assuming the pressures, ps, for zones A and C equal to +16 psf, Zones B and D equal to +8 psf, while assuming ps for Zones E, F, G, and H are equal to 0 psf.

Component & Cladding Design Wind Press

$$\text{Design Wind Pressure} = \text{Lambda} * \text{Kzt} * \text{Ps30} \text{ pe}$$

Roof Pressures	Positive	Negative	Overhang Pressures	Negative
Zone 1	12.460	-48.580 psf	Zone 1	*** psf
Zone 1'	12.460	-27.860 psf	Zone 1'	*** psf
Zone 2	12.460	-63.980 psf	Zone 2	-53.900 psf
Zone 2e	***	*** psf	Zone 2e	*** psf
Zone 2n	***	*** psf	Zone 2n	*** psf
Zone 2r	***	*** psf	Zone 2r	*** psf
Zone 3	12.460	-87.220 psf	Zone 3	-73.080 psf
Zone 3e	***	*** psf	Zone 3e	*** psf
Zone 3r	***	*** psf	Zone 3r	*** psf

Wall Pressures

Wall Zone 4 : *** *** psf
 Wall Zone 5 : *** *** psf

*** : There is no value in Figure 30.4-1 Tabular Values



ASCE Seismic Base Shear

Lic. #: KW-06011847

Mercer Island EQ

Risk Category

Calculations per ASCE 7-16

Risk Category of Building or Other Structure: "II": All Buildings and other structures except those listed as Category I, III, and IV *ASCE 7-16, Page 4, Table 1.5-1*

Seismic Importance Factor = 1 *ASCE 7-16, Page 5, Table 1.5-2*
ASCE 7-16 11.4.2

Max. Ground Motions, 5% Damping
 $S_S = 1.472$ g, 0.2 sec response
 $S_1 = 0.5664$ g, 1.0 sec response
 Latitude = 47.569 deg North
 Longitude = 122.232 deg West
 Location Mercer Island, WA 98040

Site Class, Site Coeff. and Design Category

Site Classification "D": Shear Wave Velocity 600 to 1,200 ft/sec = **D** (Based on Testing) *ASCE 7-16 Table 20.3-1*

Site Coefficients F_a & F_v
(using straight-line interpolation from table val)
 $F_a = 1.00$
 $F_v = 1.77$ *ASCE 7-16 Table 11.4-1 & 11.4-2*

Maximum Considered Earthquake Acceleration
 $S_{MS} = F_a * S_S = 1.472$ *ASCE 7-16 Eq. 11.4-1*
 $S_{M1} = F_v * S_1 = 1.000$ *ASCE 7-16 Eq. 11.4-2*

Design Spectral Acceleration
 $S_{DS} = S_{MS} * 2/3 = 0.981$ *ASCE 7-16 Eq. 11.4-3*
 $S_{D1} = S_{M1} * 2/3 = 0.667$ *ASCE 7-16 Eq. 11.4-4*

Seismic Design Category = **D** *E 7-16 Table 11.6-1 & -2*

Resisting System

ASCE 7-16 Table 12.2-1

Basic Seismic Force Resisting System **Bearing Wall Systems**
15.Light-frame (wood) walls sheathed w/wood structural panels rated for shear resistance.

Response Modification Coefficient "I" = 6.50
 System Overstrength Factor "Wo" = 3.00
 Deflection Amplification Factor "Cd" = 4.00
 Building height Limits:
 Category "A & B" Limit: No Limit
 Category "C" Limit: No Limit
 Category "D" Limit: Limit = 65
 Category "E" Limit: Limit = 65
 Category "F" Limit: Limit = 65

NOTE! See ASCE 7-16 for all applicable footnc

Lateral Force Procedure

ASCE 7-16 Section 12.8.2

Equivalent Lateral Force Procedure

The "Equivalent Lateral Force Procedure" is being used according to the provisions of ASCE 7-16 12.8

Determine Building Period

Use ASCE 12.8-7

Structure Type for Building Period Calculation **All Other Structural Systems**
 "Ct" value = 0.020 "hn": Height from base to highest level = 30.0 ft
 "x" value = 0.75
 "Ta" Approximate fundamental period using Eq. 12.8-7: $T_a = C_t * (h_n \wedge x) = 0.256$ sec
 "TL": Long-period transition period per ASCE 7-16 Maps 22-14 -> 22-17 = 6.000 sec

= 0.256 sec

"Cs" Response Coefficient

ASCE 7-16 Section 12.8.1.1

S_{DS} : Short Period Design Spectral Response = 0.981 From Eq. 12.8-2, Preliminary C_s = 0.151
 "R": Response Modification Factor = 6.50 From Eq. 12.8-3 & 12.8-4, C_s need not exceed = 0.400
 "I": Seismic Importance Factor = 1 From Eq. 12.8-5 & 12.8-6, C_s not be less than = 0.043

C_s : Seismic Response Coefficient = 0.1510

Seismic Base Shear

ASCE 7-16 Section 12.8.1

$C_s = 0.1510$ from 12.8.1.1
 W (see Sum W_i below) = 161.50 k
 Seismic Base Shear $V = C_s * W = 24.38$ k



Project Title: Mercer Island Custom Home
 Engineer: KJH
 Project ID: 21-045
 Project Descr: Framing and Foundations

Printed: 9 AUG 2021, 12:29AM

ASCE Seismic Base Shear

Software copyright ENERCALC, INC. 1983-2020, Build:12.20.8.24

Lic. #: KW-06011847

Merrell Design Services PLLC

Vertical Distribution of Seismic Forces

ASCE 7-16 Section 12.8.3

"k": hx exponent based on Ta = 1.00

Table of building Weights by Floor Level...

Level #	Wi : Weight	Hi : Height	(Wi * Hi^k)	Cvx	Fx=Cvx * V	Sum Story Shear	Sum Story Moment	
3	31.30	30.00	939.00	0.3124	7.62	7.62	0.00	
2	69.50	21.00	1,459.50	0.4856	11.84	19.46	68.56	
1	60.70	10.00	607.00	0.2020	4.92	24.38	282.60	
Sum Wi =	161.50 k	Sum Wi * Hi =	3,005.50 k-ft		Total Base Shear =	24.38 k	Base Moment =	526.4 k-ft

Diaphragm Forces : Seismic Design Category "B" to "F"

ASCE 7-16 12.10.1.1

Level #	Wi	Fi	Sum Fi	Sum Wi	Fpx : Calcd	Fpx : Min	Fpx : Max	Fpx	Dsgn. Force
3	31.30	7.62	7.62	31.30	7.62	6.14	12.29	7.62	7.62
2	69.50	11.84	19.46	100.80	13.42	13.64	27.28	13.64	13.64
1	60.70	4.92	24.38	161.50	9.16	11.91	23.83	11.91	11.91

Wpx Weight at level of diaphragm and other structure elements attached to it.

Fi Design Lateral Force applied at the level.

Sum Fi Sum of "Lat. Force" of current level plus all levels above

MIN Req'd Force @ Level ... $0.20 * S_{DS} * I * W_{px}$

MAX Req'd Force @ Level ... $0.40 * S_{DS} * I * W_{px}$

Fpx : Design Force @ Level . $W_{px} * \text{SUM}(x->n) Fi / \text{SUM}(x->n) wi$, x = Current level, n = Top Level

Lateral Force Distribution

Main Wind Force (ult): 17.78 psf (zone c)
Main Wind Force (service): 10.668 psf (zone c)
Bldg Width: 40 ft
Bldg Length: 48 ft
1st Flr Width: 48 ft
2nd Flr Length: 48 ft

Seismic Mass

Roof: 31300 lbs
2nd: 69500 lbs
1st: 60700 lbs

Level	Transverse Loads				Longitudinal Loads				Floor ht ft
	Seismic Weight (k)	Seismic Force (k)	Service Level Forces (k)	Wind Trib ht ft	Svc Lvl EQ Unit Forces Trans lbs/ft	Service Wind Loads Trans lbs/ft	Svc Lvl EQ Unit Forces Long lbs/ft	Service Wind Loads Long lbs/ft	
Roof	31300	7.62	5.33	7.5	111	80	133	80	9
2nd	69500	11.84	8.29	10	173	107	247	107	11
Main	60700	4.92	3.44	5	72	53	103	53	10

Total: 24.38 17.07
Seismic loads control lateral loads in both directions Transverse Wind Total: 11.5 k
Longititude Wind Total: 9.6 k

Transverse Direction Shear Walls

Grid	Roof Trib width (ft)	Roof (lbs)	Lenth of SW (ft)	2nd floor walls (lb/ft)	SW Type	DL Resistance lbs/ft	HD force lbs	HD Type	1st Trib width (ft)	1st Floor (lbs)	Lenth of SW (ft)	1st Floor walls (lb/ft)	SW Type	DL Resistance lbs/ft	HD force lbs	HD Type	Basement Trib width (ft)	Basement (lbs)	Lenth of SW (ft)	Basement walls (lb/ft)	SW Type	DL Resistance lbs/ft	HD force lbs	HD Type
A	22.5	2500	18.75	133	W6	66	365	LSTA30	24	4144	31	214	W6	84	1782	HUD2	24	1722	40	147	W6	84	866	NA
C	22.5	2500	4	625	W2	66	5278	HDU5	24	1722	4	1056	2W2	125	4487	MST148/HDU4	24	1722	21.5	276	W6	84	0	NA

Longitudinal Direction Shear Walls

Grid	Roof Trib width (ft)	Roof (lbs)	Lenth of SW (ft)	2nd floor walls (lb/ft)	SW Type	DL Resistance lbs/ft	HD force lbs	HD Type	1st Trib width (sq ft)	1st Floor (lbs)	Lenth of SW (ft)	1st Floor walls (lb/ft)	SW Type	DL Resistance lbs/ft	HD force lbs	HD Type	Basement Trib width (sq ft)	Basement (lbs)	Lenth of SW (ft)	Basement walls (lb/ft)	SW Type	DL Resistance lbs/ft	HD force lbs	HD Type
1	10	1334	20.17	66	W6	138	0	NA	10	2467	18.25	208	W6	372	0	NA	10	2467	18.25	270	W6	598	0	NA
2	20	2667	4	667	2W4	138	5725	MSTC66	20	4933	9	844	2W3	372	10282	(2) MSTC66	20	2050	23	420	W3	750	0	NA
3	10	1334	12	111	W6	120	280	LSTA30	10	2467	12	317	W4	354	2360	NA	10	2467	12	411	W6	598	2844	NA

This Wall in File:

Emercalc EARTH (c) 1987-2019, Build 11.20.03.31
License : KW-06011847
License To : tj, KW-06011847

Restrained Retaining Wall

Code: IBC 2018,ACI 318-14,TMS 402-16

Criteria

Retained Height	=	10.50 ft
Wall height above soil	=	0.00 ft
Total Wall Height	=	10.50 ft
Top Support Height	=	10.00 ft
Slope Behind Wall	=	0.00
Height of Soil over Toe	=	6.00 in

Soil Data

Allow Soil Bearing	=	2,000.0 psf
Equivalent Fluid Pressure Method		
At-Rest Heel Pressure	=	32.0 psf/ft
Passive Pressure	=	150.0 psf/ft
Soil Density	=	110.00 pcf
Footing Soil Frictior	=	0.400
Soil height to ignore for passive pressure	=	12.00 in

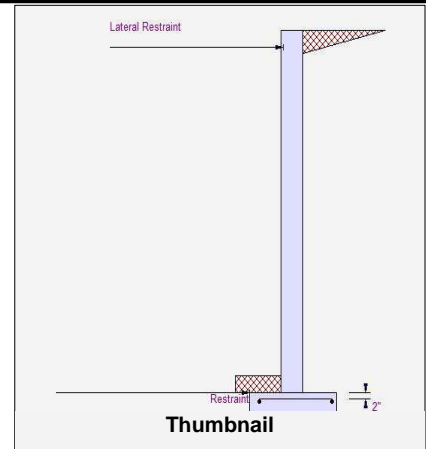

Surcharge Loads

Surcharge Over Heel	=	0.0 psf
>>>Used To Resist Sliding & Overturning		
Surcharge Over Toe	=	0.0 psf
Used for Sliding & Overturning		

Axial Load Applied to Stem

Axial Dead Load	=	750.0 lbs
Axial Live Load	=	800.0 lbs
Axial Load Eccentricity	=	0.0 in

Earth Pressure Seismic Load

Uniform Lateral Load Applied to Stem

Lateral Load	=	0.0 #/ft
...Height to Top	=	0.00 ft
...Height to Bottom	=	0.00 ft
Load Type	=	Wind (W) (Strength Level)

Wind on Exposed Stem = 0.0 psf

Adjacent Footing Load

Adjacent Footing Load	=	0.0 lbs
Footing Width	=	0.00 ft
Eccentricity	=	0.00 in
Wall to Ftg CL Dist	=	0.00 ft
Footing Type	=	Line Load
Base Above/Below Soil at Back of Wall	=	0.0 ft
Poisson's Ratio	=	0.300

K_h Soil Density Multiplier = 0.200 g Added seismic per unit area = 161.7 psf

Design Summary

Total Bearing Load	=	4,557 lbs
...resultant ecc.	=	0.00 in
Soil Pressure @ Toe	=	1,519 psf OK
Soil Pressure @ Heel	=	1,519 psf OK
Allowable	=	2,000 psf
Soil Pressure Less Than Allowable		
ACI Factored @ Toe	=	1,929 psf
ACI Factored @ Heel	=	1,929 psf
Footing Shear @ Toe	=	1.4 psi OK
Footing Shear @ Heel	=	11.7 psi OK
Allowable	=	82.2 psi
Reaction at Top	=	1,066.2 lbs
Reaction at Bottom	=	2,863.9 lbs

Sliding Calcs

Lateral Sliding Force	=	2,863.9 lbs
-----------------------	---	-------------

Concrete Stem Construction

Thickness	=	8.00 in	F_y	=	60,000 psi
Wall Weight	=	96.7 psf	f'_c	=	3,000 psi
Stem is FIXED to top of footing					

	@ Top Support	Mmax Between Top & Base	@ Base of Wall
Design Height Above Ftg	Stem OK = 10.00 ft	Stem OK = 5.94 ft	Stem OK = 0.00 ft
Rebar Size	= # 6	= # 6	= # 6
Rebar Spacing	= 12.00 in	= 12.00 in	= 12.00 in
Rebar Placed at	= Center	= Center	= Center
Rebar Depth 'd'	= 4.00 in	= 4.00 in	= 4.00 in

Design Data

fb/FB + fa/Fa	=	0.004	0.466	0.935
Mu....Actual	=	29.9 ft-#	3,288.1 ft-#	6,606.0 ft-#
Mn * Phi....Allowable	=	7,063.3 ft-#	7,063.3 ft-#	7,063.3 ft-#
Shear Force @ this height	=	1,478.7 lbs		3,647.3 lbs
Shear.....Actual	=	30.81 psi		75.98 psi
Shear.....Allowable	=	82.16 psi		82.16 psi

Vertical component of active lateral soil pressure IS NOT considered in the calculation of soil bearing

Load Factors

Building Code	IBC 2018,ACI
Dead Load	1.200
Live Load	1.600
Earth, H	1.600
Wind, W	1.000
Seismic, E	1.000

This Wall in File:

Enercalc EARTH (c) 1987-2019, Build 11.20.03.31
License : KW-06011847
License To : tj, KW-06011847

Restrained Retaining Wall

Code: IBC 2018,ACI 318-14,TMS 402-16

Concrete Stem Rebar Area Details

Top Support	Vertical Reinforcing	Horizontal Reinforcing
As (based on applied moment) :	0.0018 in2/ft	
(4/3) * As :	0.0024 in2/ft	Min Stem T&S Reinf Area 1.920 in2
200bd/fy : 200(12)(4)/60000 :	0.16 in2/ft	Min Stem T&S Reinf Area per ft of stem Height : 0.192 in2/ft
0.0018bh : 0.0018(12)(8) :	0.1728 in2/ft	Horizontal Reinforcing Options :
	=====	One layer of : Two layers of :
Required Area :	0.1728 in2/ft	#4@ 12.50 in #4@ 25.00 in
Provided Area :	0.44 in2/ft	#5@ 19.38 in #5@ 38.75 in
Maximum Area :	0.6503 in2/ft	#6@ 27.50 in #6@ 55.00 in

Mmax Between Ends	Vertical Reinforcing	Horizontal Reinforcing
As (based on applied moment) :	0.1985 in2/ft	
(4/3) * As :	0.2646 in2/ft	Min Stem T&S Reinf Area 0.779 in2
200bd/fy : 200(12)(4)/60000 :	0.16 in2/ft	Min Stem T&S Reinf Area per ft of stem Height : 0.192 in2/ft
0.0018bh : 0.0018(12)(8) :	0.1728 in2/ft	Horizontal Reinforcing Options :
	=====	One layer of : Two layers of :
Required Area :	0.1985 in2/ft	#4@ 12.50 in #4@ 25.00 in
Provided Area :	0.44 in2/ft	#5@ 19.38 in #5@ 38.75 in
Maximum Area :	0.6503 in2/ft	#6@ 27.50 in #6@ 55.00 in

Base Support	Vertical Reinforcing	Horizontal Reinforcing
As (based on applied moment) :	0.3988 in2/ft	
(4/3) * As :	0.5317 in2/ft	Min Stem T&S Reinf Area 1.141 in2
200bd/fy : 200(12)(4)/60000 :	0.16 in2/ft	Min Stem T&S Reinf Area per ft of stem Height : 0.192 in2/ft
0.0018bh : 0.0018(12)(8) :	0.1728 in2/ft	Horizontal Reinforcing Options :
	=====	One layer of : Two layers of :
Required Area :	0.3988 in2/ft	#4@ 12.50 in #4@ 25.00 in
Provided Area :	0.44 in2/ft	#5@ 19.38 in #5@ 38.75 in
Maximum Area :	0.6503 in2/ft	#6@ 27.50 in #6@ 55.00 in

Footing Strengths & Dimensions

Toe Width	=	1.17 ft
Heel Width	=	1.83
Total Footing Width	=	3.00
Footing Thickness	=	16.00 in
Key Width	=	12.00 in
Key Depth	=	0.00 in
Key Distance from Toe	=	2.00 ft
f'c =	3,000 psi	Fy = 60,000 psi
Footing Concrete Density	=	145.00 pcf
Min. As %	=	0.0018
Cover @ Top	=	2.00 in @ Btm.= 3.00 in

Footing Design Results

	Toe	Heel
Factored Pressure	= 1,929	1,929 psf
Mu' : Upward	= 1,313	0 ft-#
Mu' : Downward	= 203	1,101 ft-#
Mu: Design	= 1,110	1,101 ft-#
Actual 1-Way Shear	= 1.36	11.65 psi
Allow 1-Way Shear	= 82.16	82.16 psi

Other Acceptable Sizes & Spacings:

Toe: # 6 @ 13.58 in	-or-	phiMn = phi'5'lambda'sqrt(fc)'Sm
Heel: # 6 @ 16.00 in	-or-	phiMn = phi'5'lambda'sqrt(fc)'Sm
Key: Slab Resists Sliding	-or-	Slab Resists Sliding - No Force on
Min footing T&S reinf Area		1.04 in2
Min footing T&S reinf Area per foot		0.35 in2 /ft
If one layer of horizontal bars:		If two layers of horizontal bars:
#4@ 6.94 in		#4@ 13.89 in
#5@ 10.76 in		#5@ 21.53 in
#6@ 15.28 in		#6@ 30.56 in

This Wall in File:

Enercalc EARTH (c) 1987-2019, Build 11.20.03.31
License : KW-06011847
License To : tj, KW-06011847

Restrained Retaining Wall

Code: IBC 2018,ACI 318-14,TMS 402-16

Summary of Forces on Footing : Slab RESISTS sliding, stem is FIXED at footing

Forces acting on footing for soil pressure

>>> Sliding Forces are restrained by the adjacent slab

Load & Moment Summary For Footing : For Soil Pressure Calcs

Moment @ Top of Footing Applied from Stem	=		=	-4,344.2 ft-#
Surcharge Over Heel	=	lbs	ft	ft-#
Adjacent Footing Load	=	lbs	ft	ft-#
Axial Dead Load on Stem	=	1,550.0 lbs	1.50 ft	2,325.0 ft-#
Soil Over Toe	=	64.2 lbs	0.58 ft	37.4 ft-#
Surcharge Over Toe	=	lbs	ft	ft-#
Stem Weight	=	1,015.0 lbs	1.50 ft	1,522.5 ft-#
Soil Over Heel	=	1,347.5 lbs	2.42 ft	3,256.5 ft-#
Footing Weight	=	580.0 lbs	1.50 ft	870.5 ft-#
Total Vertical Force	=	4,556.7 lbs	Base Moment =	3,667.7 ft-#

Soil Pressure Resulting Moment = 0.0ft-#

Vertical component of active lateral soil pressure IS NOT considered in the calculation of Sliding Resistance.

This Wall in File:

Enercalc EARTH (c) 1987-2019, Build 11.20.03.31
License : KW-06011847
License To : tj, KW-06011847

Restrained Retaining Wall

Code: IBC 2018,ACI 318-14,TMS 402-16

Rebar Lap & Embedment Lengths Information

(Applying TMS 402 provisions) or (Applying IBC modifications to TMS 402 provisions)

Stem Design Segment Near Top Support

Stem Design Height: 10.00 ft above top of footing

Lap Splice length for #6 bar specified in this stem design segment = 25.63 in
Development length for #6 bar specified in this stem design segment = 19.72 in

Stem Design Segment at Mmax Between Ends

Stem Design Height: 5.94 ft above top of footing

Lap Splice length for #6 bar specified in this stem design segment = 25.63 in
Development length for #6 bar specified in this stem design segment = 19.72 in

Stem Design Segment at Base Support

Stem Design Height: 0.00 ft above top of footing

Lap Splice length for #6 bar specified in this stem design segment = 25.63 in
Development length for #6 bar specified in this stem design segment = 19.72 in

Hooked embedment length into footing for #6 bar specified in this stem design segment = 10.42 in
As Provided = 0.4400 in2/ft
As Required = 0.3988 in2/ft

This Wall in File:

Enercalc EARTH (c) 1987-2019, Build 11.20.03.31
License : KW-06011847
License To : tj, KW-06011847

Restrained Retaining Wall

Code: IBC 2018,ACI 318-14,TMS 402-16

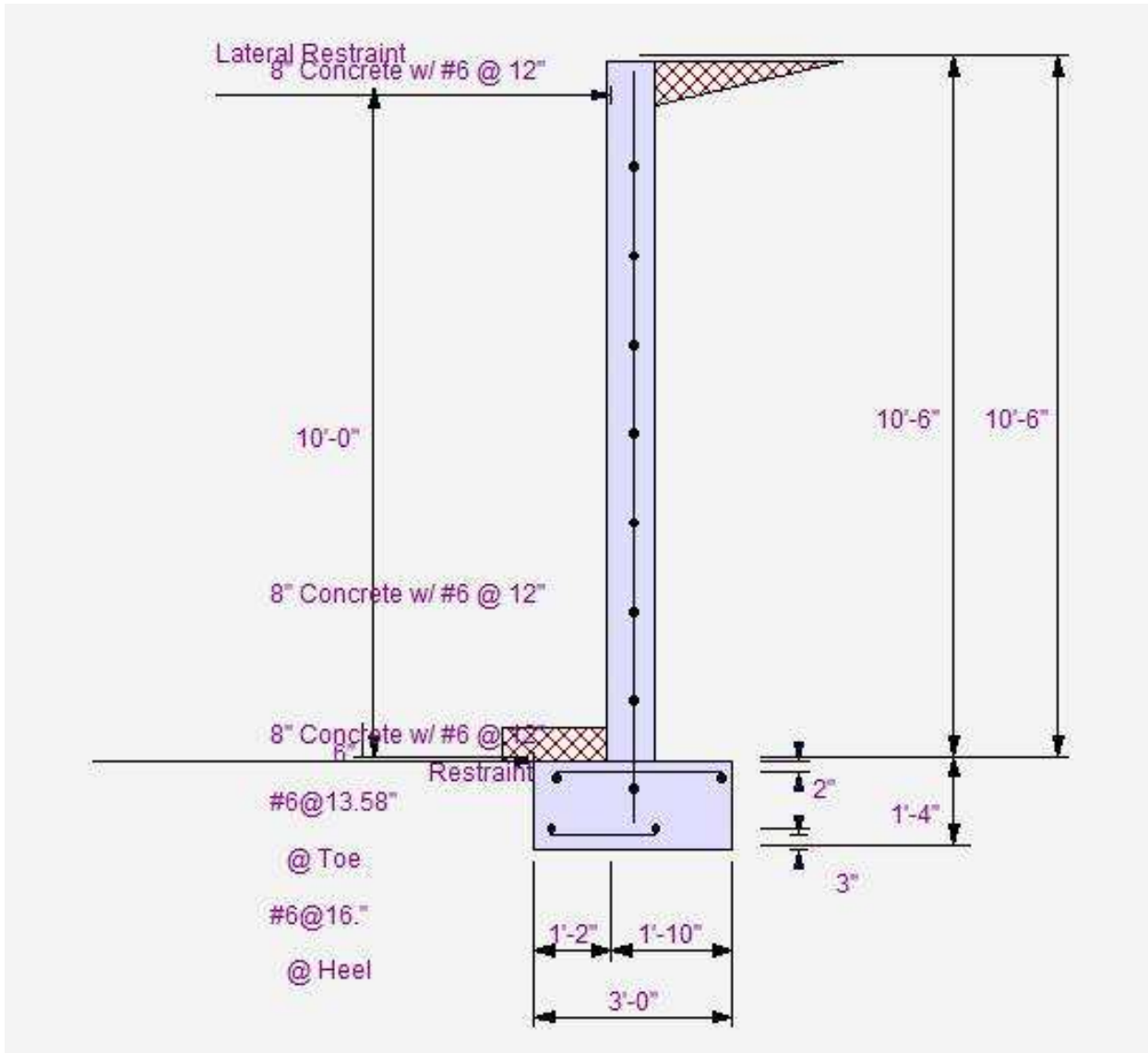

This Wall in File:

Enercalc EARTH (c) 1987-2019, Build 11.20.03.31
License : KW-06011847
License To : tj, KW-06011847

Cantilevered Retaining Wall

Code: IBC 2018,ACI 318-14,TMS 402-16

Criteria

Retained Height	=	10.50 ft
Wall height above soil	=	0.50 ft
Slope Behind Wall	=	0.00
Height of Soil over Toe	=	6.00 in
Water height over heel	=	0.0 ft

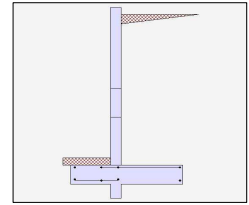

Load Factors

Building Code	IBC 2018,ACI
Dead Load	1.200
Live Load	1.600
Earth, H	1.600
Wind, W	1.000
Seismic, E	1.000

Soil Data and Lateral Earth Pressure

Allow Soil Bearing	=	2,000.0 psf	Soil Density, Heel	=	110.00 pcf
Equivalent Fluid Pressure Method			Soil Density, Toe	=	110.00 pcf
Active Heel Pressure	=	32.0 psf/ft	Footing Soil Friction	=	0.350
	=		Soil height to ignore for passive pressure	=	6.00 in
Passive Pressure	=	150.0 psf/ft			

Surcharge Loads

Surcharge Over Heel	=	0.0 psf	Surcharge Over Toe	=	40.0 psf
Used To Resist Sliding & Overturning			Used for Sliding & Overturning		

Axial Load Applied to Stem

Axial Dead Load	=	750.0 lbs	Axial Load Eccentricity	=	0.0 in
Axial Live Load	=	800.0 lbs			

Lateral Load Applied to Stem

Lateral Load	=	0.0 #/ft
...Height to Top	=	0.00 ft
...Height to Bottom	=	0.00 ft
Load Type	=	Wind (W) (Service Level)

Wind on Exposed Stem

Wind on Exposed Stem (Service Level)	=	0.0 psf
--------------------------------------	---	---------

Adjacent Footing Load

Adjacent Footing Load	=	0.0 lbs	Footing Type	Line Load	
Footing Width	=	0.00 ft	Base Above/Below Soil		
Eccentricity	=	0.00 in	at Back of Wall	=	0.0 ft
Wall to Ftg CL Dist	=	0.00 ft	Poisson's Ratio	=	0.300

This Wall in File:

Enercalc EARTH (c) 1987-2019, Build 11.20.03.31
License : KW-06011847
License To : tj, KW-06011847

Cantilevered Retaining Wall

Code: IBC 2018,ACI 318-14,TMS 402-16

Earth Pressure Seismic Load

Method : Uniform

Multiplier Used	=	0.200	Uniform Seismic Force	=	2.367
(Multiplier used on soil density)			Total Seismic Force	=	28.006

Stem Weight Seismic Load

F_p / W_p Weight Multiplier	=	0.200 g	Added seismic base force	=	-154.0 lbs
-------------------------------	---	---------	--------------------------	---	------------

Seismic Self-Weight acts left-to-right toward retention side.

This Wall in File:

Enercalc EARTH (c) 1987-2019, Build 11.20.03.31
License : KW-06011847
License To : tj, KW-06011847

Cantilevered Retaining Wall

Code: IBC 2018,ACI 318-14,TMS 402-16

Wall Design Summary**Stability Ratios**

Overturning	=	5.11 OK
Sliding	=	1.52 OK

Soil Bearing

Total Bearing Load	=	8,765 lbs
...resultant ecc.	=	4.46 in
Soil Pressure @ Toe	=	1,651 psf OK
Soil Pressure @ Heel	=	853 psf OK
Allowable	=	2,000 psf
Soil Pressure Less Than Allowable		
ACI Factored @ Toe	=	2,311 psf
ACI Factored @ Heel	=	1,195 psf
Footing Shear @ Toe	=	17.6 psi OK
Footing Shear @ Heel	=	13.1 psi OK
Allowable	=	75.0 psi

Sliding**Resisting Forces****Sliding Forces**

<u>Vertical Forces</u>	<u>Force</u>	<u>Lateral Forces</u>	<u>Force</u>
Soil Over Heel (above water table, if any)	4,427.5 lbs	Heel Active Pressure (above water table, if any)	2,240.4 lbs
Soil Over Heel (below water table, if any)	0.0	Heel Active Pressure (below water table, if any)	0.0
Water Over Heel	0.0	Hydrostatic Force	0.0
Buoyant Force	0.0	* Heel Active Pressure	2,240.4
Sloped Soil Over Heel	0.0	Surcharge over Heel	0.0
Surcharge Over Heel	0.0	Adjacent Footing	0.0
Adjacent Footing Load	0.0	Surcharge Over Toe	0.0
Axial Dead Load on Stem	1,550.0	Load @ Stem Above Soil	0.0
Axial Live Load on Stem *	Omit	Added Lateral Load	0.0
Soil Over Toe	137.5	Seismic Load	19.6
Surcharge Over Toe	100.0	Seismic-Self-weight	-154.0
Stem Weight(s)	1,100.0	Lateral on Key	0.0
Earth @ Stem Transitions	0.0		
Footing Weight	1,353.3	Totals =	2,106.0 lbs
Key Weight	96.7		
Vert. Component **	1,040.7	*Includes water table effect	
Total Vertical Loads	9,005.7 lbs		

* Axial live load NOT included in total displayed , or used for overturning or sliding resistance, but is included for soil pressure calculations.

Sliding Calcs

Lateral Sliding Force	=	2,106.0 lbs
less 6 % Passive Force	=	- 44.9 lbs
less 100% Friction Force	=	- 3,152.0 lbs
Added Force Req'd	=	0.0 lbs OK
....for 1.5 Stability	=	0.0 lbs OK

Vertical component of active lateral soil pressure IS NOT considered in the calculation of soil bearing pressures.

This Wall in File:

Enercalc EARTH (c) 1987-2019, Build 11.20.03.31
License : KW-06011847
License To : tj, KW-06011847

Cantilevered Retaining Wall

Code: IBC 2018,ACI 318-14,TMS 402-16

Overturning**Resisting Moments**

<u>Resisting Moments</u>	<u>Force</u>	<u>Distance</u>	<u>Moment</u>
Soil Over Heel (above water table, if any)	4,427.5	lbs 5.08 ft	22,506.5ft-#
Soil Over Heel (below water table, if any)	0.0		
Water Table	0.0		
Soil Over Heel	4,427.5	5.08	22,506.5
Sloped Soil Over Heel	0.0		
Surcharge Over Heel	0.0		
Adjacent Footing Load	0.0		
Axial Dead Load on Stem	1,550.0	2.83	2,125.0
Axial Live Load on Stem *	800.0	2.83	2,266.7
Soil Over Toe	137.5	1.25	171.9
Surcharge Over Toe	100.0	1.25	125.0
Stem Weight(s)	1,100.0	2.83	3,116.7
Earth @ Stem Transitions	0.0		
Footing Weight	1,353.3	3.50	4,736.7
Key Weight	96.7	2.83	273.9
Vert. Component	1,040.7	7.00	7,284.8
Total Vertical Loads	9,005.7	lbs	

Resisting Moment 40,340.4 ft-#

Eccentricity 1.2 in

* Axial live load NOT included in total displayed, or used for overturning or sliding resistance, but is included for soil pressure calculations.

Overturning**Overturning Moments**

<u>Overturning Moments</u>	<u>Force</u>	<u>Distance</u>	<u>Moment</u>
Heel Active Pressure (above water table, if any)	2,240.4	lbs 3.94 ft	8,837.3 ft-#
Heel Active Pressure (below water table, if any)	0.0		
Hydrostatic Force	0.0		
Buoyant Force	0.0		
Surcharge over Heel	0.0		
Adjacent Footing	0.0		
Surcharge Over Toe	0.0		
Load @ Stem Above Soil	0.0		
Added Lateral Load	0.0		
Seismic Load	19.6	5.92	116.0
Seismic-Self-weight	-154.0	6.83	-1,052.3
Totals =	2,106.0	lbs	
	Overturning Moment		<u>7,901.0 ft-#</u>

This Wall in File:

Enercalc EARTH (c) 1987-2019, Build 11.20.03.31
License : KW-06011847
License To : tj, KW-06011847

Cantilevered Retaining Wall

Code: IBC 2018,ACI 318-14,TMS 402-16

Stem Design Summary

		3rd	2nd	Bottom
		Stem OK	Stem OK	Stem OK
Design Height Above Ftg	ft =	5.33	3.33	0.00
Wall Material Above "Ht"	=	Concrete	Concrete	Concrete
Design Method	=	LRFD	LRFD	LRFD
Thickness	=	8.00	8.00	8.00
Rebar Size	=	# 6	# 6	# 6
Rebar Spacing	=	16.00	16.00	12.00
Rebar Placed at	=	Edge	Edge	Edge
Design Data				
fb/FB + fa/Fa	=	0.116	0.343	0.870
Total Force @ Section				
Service Level	lbs =			
Strength Level	lbs =	583.1	1,179.6	2,627.3
Moment....Actual				
Service Level	ft-# =			
Strength Level	ft-# =	889.3	2,617.9	8,798.9
Moment.....Allowable	ft-# =	7,630.3	7,630.3	10,109.5
Shear.....Actual				
Service Level	psi =			
Strength Level	psi =	8.6	17.5	38.9
Shear.....Allowable	psi =	67.1	67.1	75.0
Anet	in2 =			
Rebar Depth 'd'	in =	5.63	5.63	5.63
Masonry Data				
f'm	psi =			
Fy	psi =	60,000		
Solid Grouting	=			
Modular Ratio 'n'	=			
Wall Weight	psf =	100.0	100.0	100.0
Equiv. Solid Thick.	=			
Masonry Block Type	=	Medium Weight		
Masonry Design Method	=	LRFD		
Concrete Data				
f'c	psi =	2,000.0	2,000.0	2,500.0
Fy	psi =	60,000.0	60,000.0	60,000.0

This Wall in File:

Enercalc EARTH (c) 1987-2019, Build 11.20.03.31
License : KW-06011847
License To : tj, KW-06011847

Cantilevered Retaining Wall

Code: IBC 2018,ACI 318-14,TMS 402-16

Concrete Stem Rebar Area Details

3rd Stem	Vertical Reinforcing	Horizontal Reinforcing
As (based on applied moment) :	0.0372 in2/ft	
(4/3) * As :	0.0497 in2/ft	Min Stem T&S Reinf Area 1.089 in2
200bd/fy : 200(12)(5.625)/60000 :	0.225 in2/ft	Min Stem T&S Reinf Area per ft of stem Height : 0.192 in2/ft
0.0018bh : 0.0018(12)(8) :	0.1728 in2/ft	Horizontal Reinforcing Options :
	=====	One layer of : Two layers of :
Required Area :	0.1728 in2/ft	#4@ 12.50 in #4@ 25.00 in
Provided Area :	0.33 in2/ft	#5@ 19.38 in #5@ 38.75 in
Maximum Area :	0.6096 in2/ft	#6@ 27.50 in #6@ 55.00 in

2nd Stem	Vertical Reinforcing	Horizontal Reinforcing
As (based on applied moment) :	0.1096 in2/ft	
(4/3) * As :	0.1462 in2/ft	Min Stem T&S Reinf Area 0.384 in2
200bd/fy : 200(12)(5.625)/60000 :	0.225 in2/ft	Min Stem T&S Reinf Area per ft of stem Height : 0.192 in2/ft
0.0018bh : 0.0018(12)(8) :	0.1728 in2/ft	Horizontal Reinforcing Options :
	=====	One layer of : Two layers of :
Required Area :	0.1728 in2/ft	#4@ 12.50 in #4@ 25.00 in
Provided Area :	0.33 in2/ft	#5@ 19.38 in #5@ 38.75 in
Maximum Area :	0.6096 in2/ft	#6@ 27.50 in #6@ 55.00 in

Bottom Stem	Vertical Reinforcing	Horizontal Reinforcing
As (based on applied moment) :	0.3685 in2/ft	
(4/3) * As :	0.4913 in2/ft	Min Stem T&S Reinf Area 0.639 in2
200bd/fy : 200(12)(5.625)/60000 :	0.225 in2/ft	Min Stem T&S Reinf Area per ft of stem Height : 0.192 in2/ft
0.0018bh : 0.0018(12)(8) :	0.1728 in2/ft	Horizontal Reinforcing Options :
	=====	One layer of : Two layers of :
Required Area :	0.3685 in2/ft	#4@ 12.50 in #4@ 25.00 in
Provided Area :	0.44 in2/ft	#5@ 19.38 in #5@ 38.75 in
Maximum Area :	0.762 in2/ft	#6@ 27.50 in #6@ 55.00 in

Footing Data

Toe Width	=	2.50 ft	f'c	=	2,500 psi
Heel Width	=	4.50	Fy	=	60,000 psi
Total Footing Width	=	7.00 ft	Footing Concrete Density	=	145.00 pcf
Footing Thickness	=	16.00 in	Min. As %	=	0.0018
Key Width	=	8.00 in	Rebar Cover @ Top	=	2.00 in
Key Depth	=	12.00 in	@ Bottom	=	3.00 in
Key Distance from Toe	=	2.50 ft			

This Wall in File:

Enercalc EARTH (c) 1987-2019, Build 11.20.03.31
License : KW-06011847
License To : tj, KW-06011847

Cantilevered Retaining Wall

Code: IBC 2018,ACI 318-14,TMS 402-16

Footing Design Results

		<u>Toe</u>	<u>Heel</u>	
Factored Pressure	=	2,311	1,195	psf
Mu' : Upward	=	81,686	10,276	ft-#
Mu' : Downward	=	13,575	18,271	ft-#
Mu: Design	=	5,676	-5,391	ft-#
Actual 1-Way Shear	=	17.61	13.06	psi
Allow 1-Way Shear	=	75.00	75.00	psi
Toe Reinforcing	=	# 6 @ 12.00 in		
Heel Reinforcing	=	# 6 @ 12.00 in		
Key Reinforcing	=	None Spec'd		

Other Acceptable Sizes & Spacings

Toe: #4@ 6.94 in, #5@ 10.76 in, #6@ 15.27 in, #7@ 20.83 in, #8@ 27.43 in, #9@ 34

Heel: #4@ 6.94 in, #5@ 10.76 in, #6@ 15.27 in, #7@ 20.83 in, #8@ 27.43 in, #9@ 34

Key: $\phi Mn = \phi'5\lambda\sqrt{fc}'Sm$

Min footing T&S reinf Area 2.42 in²
Min footing T&S reinf Area per fo 0.35 in² /ft

If one layer of horizontal bars:	If two layers of horizontal bars:
#4@ 6.94 in	#4@ 13.89 in
#5@ 10.76 in	#5@ 21.53 in
#6@ 15.28 in	#6@ 30.56 in

Footing Torsion, Tu = 0.00 ft-lbs
Footing Allow. Torsion, ϕTu = 0.00 ft-lbs

If torsion exceeds allowable, provide supplemental design for footing torsion.**Tilt****Horizontal Deflection at Top of Wall due to settlement of soil**

(Deflection due to wall bending not considered)

Soil Spring Reaction Modulus 250.0 pci
Horizontal Defl @ Top of Wall (approximate only) 0.072 in

The above calculation is not valid if the heel soil bearing pressure exceeds that of the toe, because the wall would then tend to rotate into the retained soil.

This Wall in File:

Enercalc EARTH (c) 1987-2019, Build 11.20.03.31
License : KW-06011847
License To : tj, KW-06011847

Cantilevered Retaining Wall

Code: IBC 2018,ACI 318-14,TMS 402-16

Rebar Lap & Embedment Lengths Information

Stem Design Segment: 3rd

Stem Design Height: 5.33 ft above top of footing

Lap Splice length for #6 bar specified in this stem design segment = 31.39 in

Development length for #6 bar specified in this stem design segment = 24.15 in

Stem Design Segment: 2nd

Stem Design Height: 3.33 ft above top of footing

Lap Splice length for #6 bar specified in this stem design segment = 31.39 in

Development length for #6 bar specified in this stem design segment = 24.15 in

Stem Design Segment: Bottom

Stem Design Height: 0.00 ft above top of footing

Lap Splice length for #6 bar specified in this stem design segment = 28.08 in

Development length for #6 bar specified in this stem design segment = 21.60 in

Hooked embedment length into footing for #6 bar specified in this stem design segment = 10.55 in

As Provided = 0.4400 in2/ft

As Required = 0.3685 in2/ft

This Wall in File:

Enercalc EARTH (c) 1987-2019, Build 11.20.03.31
License : KW-06011847
License To : tj, KW-06011847

Cantilevered Retaining Wall

Code: IBC 2018, ACI 318-14, TMS 402-16

